

017



Self-Retaining Retractors, Abdominal Retractors
Wundspreizer (selbsthaltend), Bauchdeckenhalter
Separadores con retenida automática, Separadores abdominales
Ecarteurs autostatiques, Ecarteurs abdominaux
Divaricatori autostatici, Divaricatori addominali



Self-Retaining Retractors

Wundspreizer, selbsthaltend
Separadores con retenida automática
Ecarteurs autostatiques
Divaricatori autostatici



017



BARRAQUER
17-640-04
4,5 cm, 1¼"



SAUER
17-644-03
3,5 cm, 1¼"



LANCASTER
17-648-08
8 cm, 3⅜"

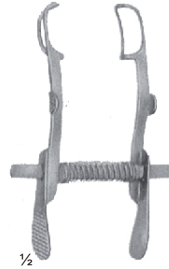

MELLINGER
17-650-01
17-650-03
7 cm, 2¾"



17-650-01



17-650-02



17-650-03

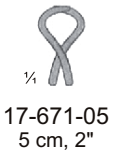

17-671-05
5 cm, 2"

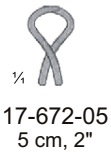

17-672-05
5 cm, 2"



17-671-07
7 cm, 2¾"



17-672-07
7 cm, 2¾"

Sharp
Spitz
Agudo
Pointu
Acuto

Blunt
Stumpf
Romo
Mousse
Smusso



FINSEN
17-671-05
17-672-07

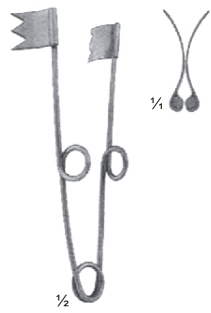

17-654-08
8,5 cm, 3¼"
17-654-11
11,5 cm, 4½"

Self-retaining retractor
Wundspreizer, selbsthaltend
Separador con retenida automática
Ecarteur autostatiques
Divaricatore autostatici



17-656-04
4,5 cm, 1¼"



17-658-05
5,5 cm, 2"



MUELLER
17-662-06
6,5 cm, 2½"



LOGAN
17-666-04
4,5 cm, 1½"

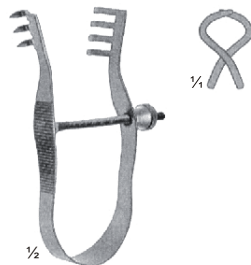

FINSEN
17-675-07
7 cm, 2¾"
17-676-07
7 cm, 2¾"

Sharp
Spitz
Agudo
Pointu
Acuto

Blunt
Stumpf
Romo
Mousse
Smusso

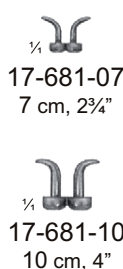

17-681-07
7 cm, 2¾"

17-681-10
10 cm, 4"

Sharp
Spitz
Agudo
Pointu
Acuto



ALM
17-681-07
17-682-10

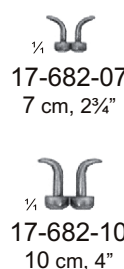

17-682-07
7 cm, 2¾"

17-682-10
10 cm, 4"

Blunt
Stumpf
Romo
Mousse
Smusso



17-687-10
10 cm, 4"

Sharp
Spitz
Agudo
Pointu
Acuto

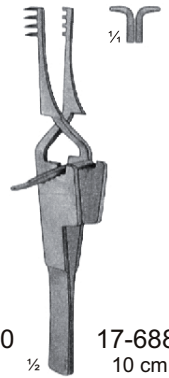

17-688-10
10 cm, 4"

Blunt
Stumpf
Romo
Mousse
Smusso

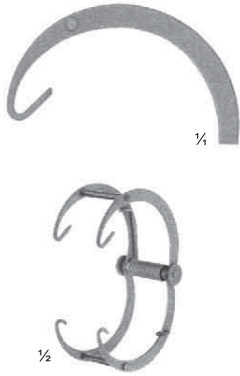

VICKERS
 17-710-04
 4,5 cm, 1¾"

Finger retractor
 Finger-Wundspreizer
 Separador para dedos
 Ecarteur pour doigts
 Divaricatore per dita



VICKERS
 17-702-09
 9 cm, 3½"

Hand and carpal tunnel retractor,
 with central valve 18 x 10mm (17-710-09)

Hand- und Carpal-Tunnel-Wundspreizer,
 mit Mittelvalve 18x10 mm (17-710-09)

Separador de mano y túnel de carpo,
 con valva central 18x10 mm (17-710-09)

Ecarteur pour mains et tunnel carpien,
 avec valve médiane 18x10 mm (17-710-09)

Divaricatore per la mano con condotto carpale,
 con valva centrale 18x10 mm (17-710-09)



VICKERS
 17-704-10
 10 cm, 4"

Deep hand and forearm retractor,
 with central valve 18x10 mm (17-712-09)

Hand- und Unterarm-Wundspreizer,
 mit Mittelvalve 18x10 mm (17-712-09)

Separador profundo para mano y antebrazo,
 con valva central 18x10 mm (17-712-09)

Ecarteur profond pour main et avant bras,
 avec valve médiane 18x10 mm (17-712-09)

Divaricatore per la mano e l'avambraccio,
 con valva centrale 18x10 mm (17-712-09)



VICKERS
 17-706-08
 8 cm, 3⅓"

Trigger finger and small wound retractor,
 with central valve 18x10 mm (17-716-08)

Schnellender Finger- und kleiner Schnitt-Wund- spreizer,
 mit Mittelvalve 18x10 mm (17-716-08)

Separador para dedos y pequeñas heridas,
 con valva central 18x10 mm (17-716-08)

Ecarteur pour doigts et petites plaies,
 avec valve médiane 18x10 mm (17-716-08)

Impugnatura a molla per dita e piccolo divaricatore per ferite,
 con valva centrale 18x10 mm (17-716-08)



17-721-10
 10 cm, 4"

Sharp
 Spitz
 Agudo
 Pointu
 Acuto



JANSEN
 17-721-10
 17-722-10

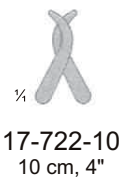

17-722-10
 10 cm, 4"

Blunt
 Stumpf
 Romo
 Mousse
 Smusso

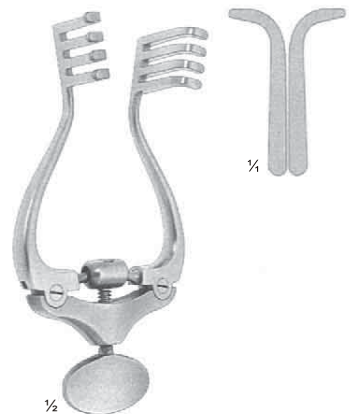

JANSEN
 17-724-11
 11 cm, 4¾"

Blunt
 Stumpf
 Romo
 Mousse
 Smusso

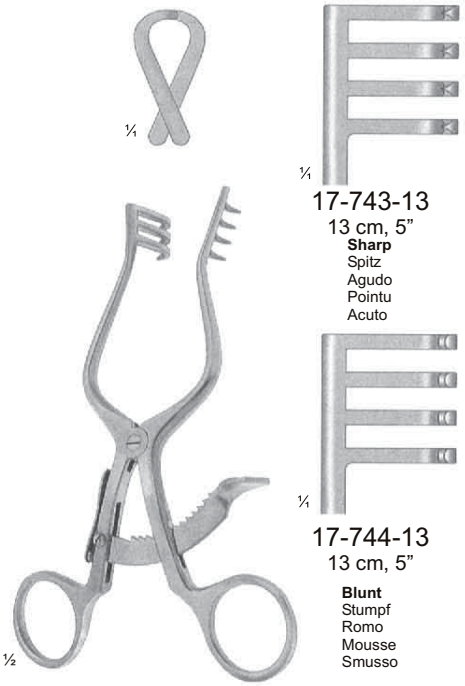

WULLSTEIN
 17-743-13
 17-744-13

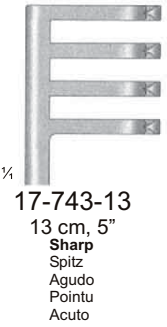

17-743-13
 13 cm, 5"
Sharp
 Spitz
 Agudo
 Pointu
 Acuto



17-744-13
 13 cm, 5"
Blunt
 Stumpf
 Romo
 Mousse
 Smusso

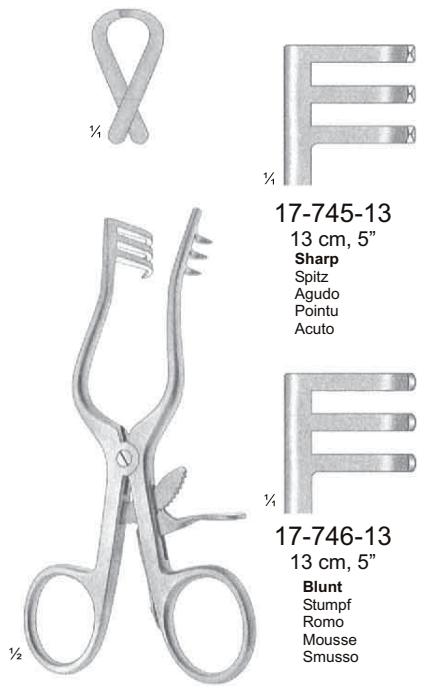

WETLANER-WULLSTEIN
 17-745-13
 17-746-13

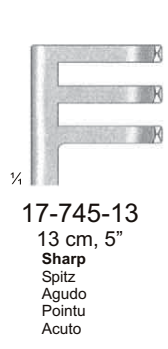

17-745-13
 13 cm, 5"
Sharp
 Spitz
 Agudo
 Pointu
 Acuto

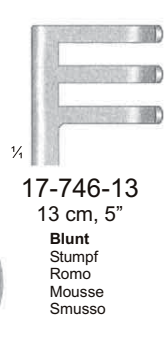

17-746-13
 13 cm, 5"
Blunt
 Stumpf
 Romo
 Mousse
 Smusso

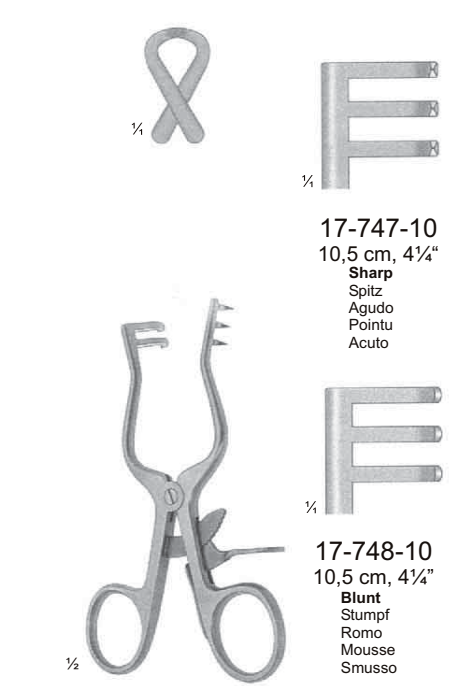

WEITLANER-LOKTITE
 17-747-10
 17-748-10

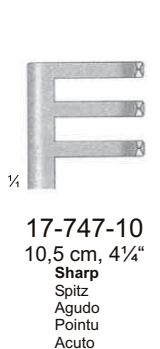

17-747-10
 10,5 cm, 4¼"
Sharp
 Spitz
 Agudo
 Pointu
 Acuto

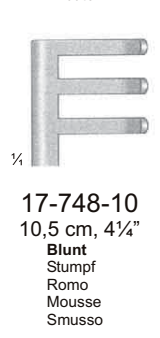

17-748-10
 10,5 cm, 4¼"
Blunt
 Stumpf
 Romo
 Mousse
 Smusso

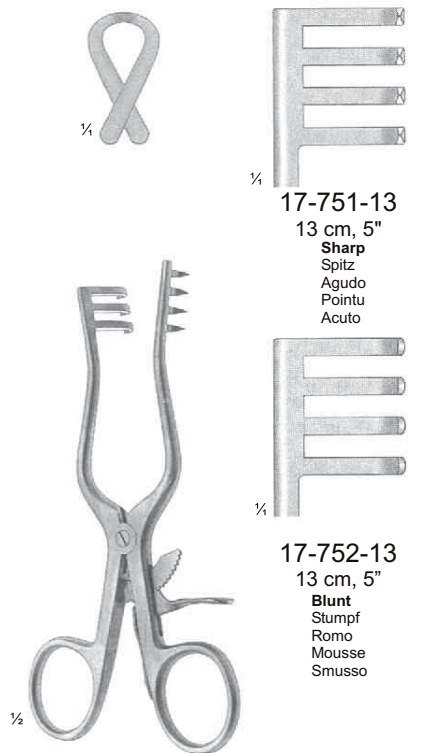

WEITLANER
 17-751-13
 17-752-13

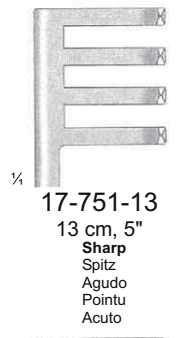

17-751-13
 13 cm, 5"
Sharp
 Spitz
 Agudo
 Pointu
 Acuto

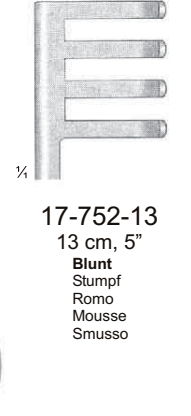

17-752-13
 13 cm, 5"
Blunt
 Stumpf
 Romo
 Mousse
 Smusso

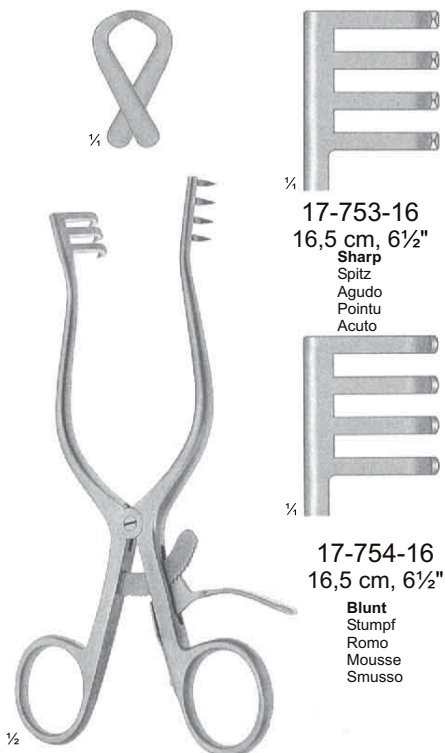

WEITLANER
 17-753-16
 17-754-16

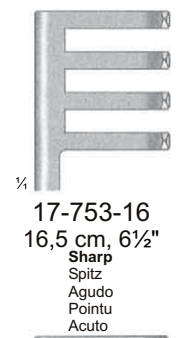

17-753-16
 16,5 cm, 6½"
Sharp
 Spitz
 Agudo
 Pointu
 Acuto



17-754-16
 16,5 cm, 6½"
Blunt
 Stumpf
 Romo
 Mousse
 Smusso

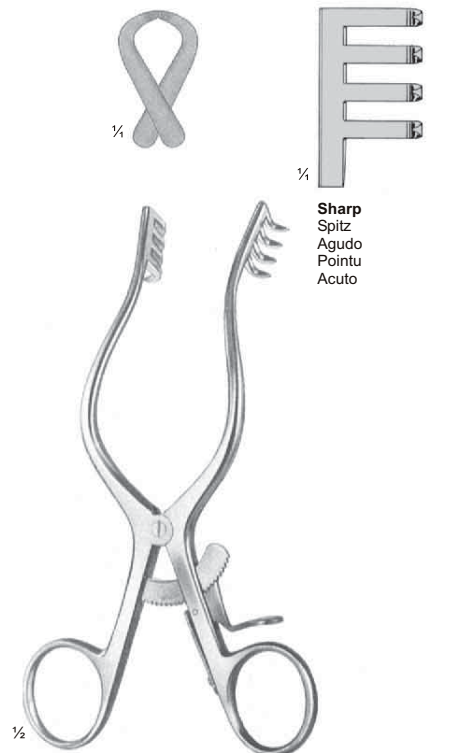

MOLLISON
 17-757-15
 15 cm, 6"

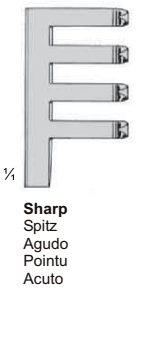

Sharp
 Spitz
 Agudo
 Pointu
 Acuto



Self-Retaining Retractors

Wundspreizer, selbsthaltend
Separadores con retenida automática
Ecarteurs autostatiques
Divaricatori autostatici



017

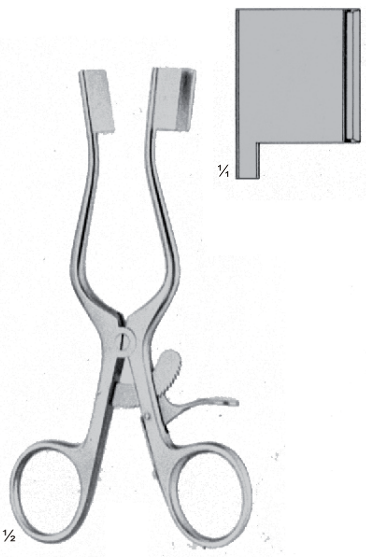

WEITLANER-BABY
17-770-13
13 cm, 5"

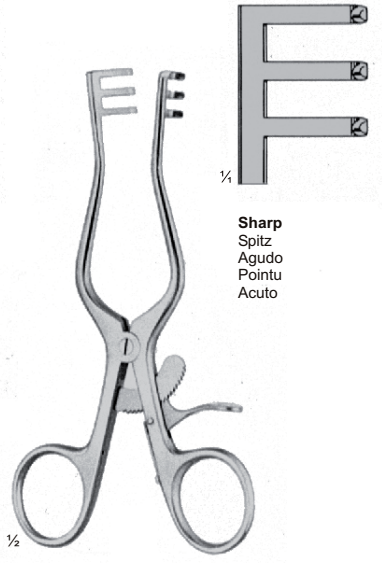

MILLIGAN
17-773-13
17-474-13
13 cm, 5"

Sharp
Spitz
Agudo
Pointu
Acuto

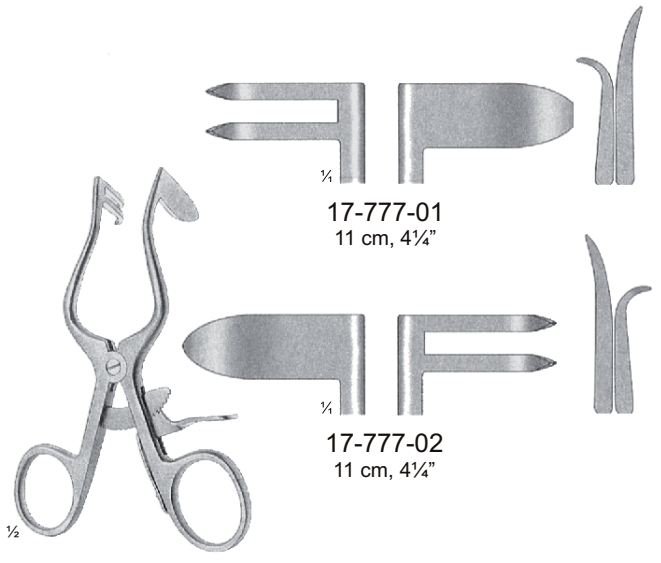

PLESTER
17-777-01
17-777-02

17-777-01
11 cm, 4 1/4"

17-777-02
11 cm, 4 1/4"

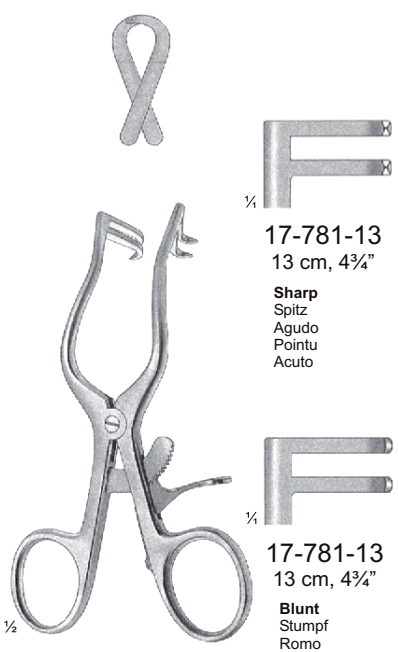

PLESTER
17-781-13
17-781-13
13 cm, 4 3/4"



17-781-13
13 cm, 4 3/4"



17-781-13
13 cm, 4 3/4"

Sharp
Spitz
Agudo
Pointu
Acuto

Blunt
Stumpf
Romo
Mousse
Smusso

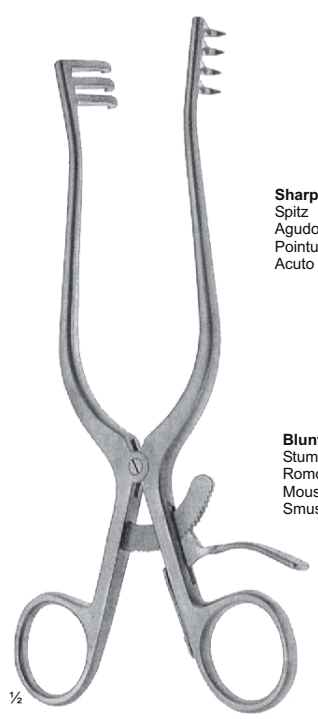

WEITLANER
17-785-01
17-786-03

Sharp
Spitz
Agudo
Pointu
Acuto

Blunt
Stumpf
Romo
Mousse
Smusso

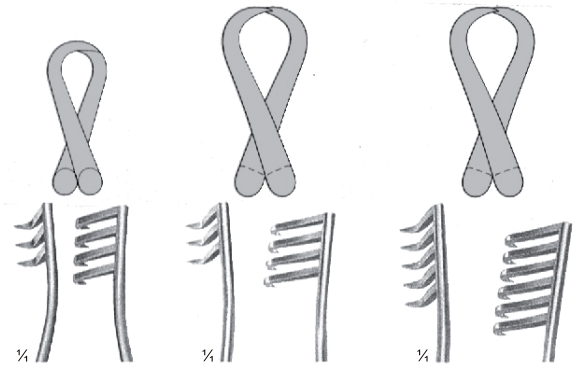

17-785-01
20 cm, 8"

17-785-02
24 cm, 9 3/4"

17-785-03
25,5 cm, 10"



17-786-01
20 cm, 8"

17-786-02
24 cm, 9 3/4"

17-786-03
25,5 cm, 10"

Retractors

Self-Retaining Retractors
 Separadores con retenida automática
 Ecarteurs autostatiques
 Divaricatori autostatici

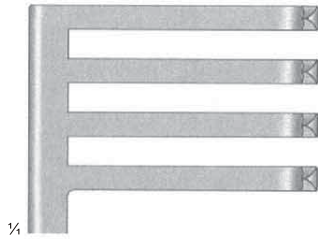

¼

Sharp
 Spitz
 Agudo
 Pointu
 Acuto

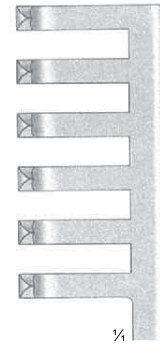

¼

17-795-27

Sharp
 Spitz
 Agudo
 Pointu
 Acuto

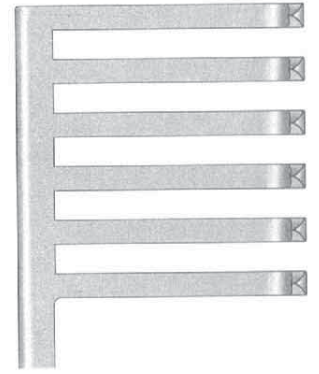

½

ADSON

17-791-26
 17-792-26
 17-793-26
 17-794-26
 26,5 cm, 10½"

Laminectomy retractor
 Laminektomie- Wundspreizer
 Separador para laminectomia
 Ecarteurs pour laminectomia
 Divaricatori per laminectomia

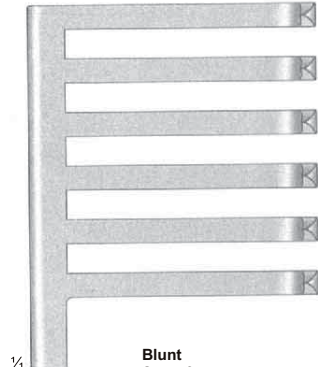

¼

Blunt
 Stumpf
 Romo
 Mousse
 Smusso



½

ADSON

17-795-27
 17-797-27
 27 cm, 10½"



¼

17-797-27

Blunt
 Stumpf
 Romo
 Mousse
 Smusso

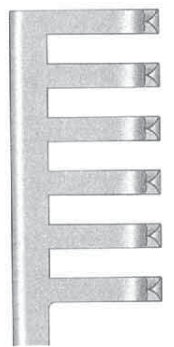



Self-Retaining Retractors

Wundspreizer, selbsthaltend
Separadores con retenida automática
Ecarteurs autostatiques
Divaricatori autostatici



017



ANDERSON-ADSON
17-801-19

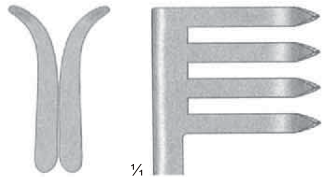

¼
17-801-19
19,5 cm, 8"
Sharp
Spitz
Agudo
Pointu
Acuto

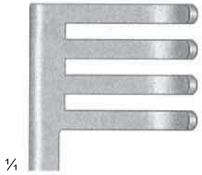

¼
17-802-19
19,5 cm, 8"
Blunt
Stumpf
Romo
Mousse
Smusso



ADSON
17-803-20
17-804-20

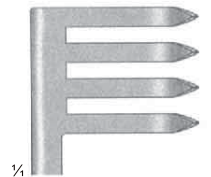

¼
17-803-20
20 cm, 8"
Sharp
Spitz
Agudo
Pointu
Acuto

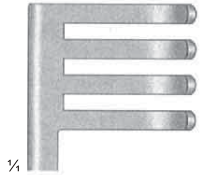

¼
17-804-20
20 cm, 8"
Blunt
Stumpf
Romo
Mousse
Smusso



Sharp
Spitz
Agudo
Pointu
Acuto

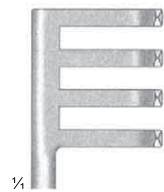

¼
17-805-13
13 cm, 5"

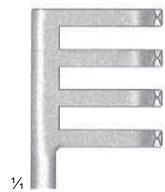

¼
17-805-16
16 cm, 6¼"

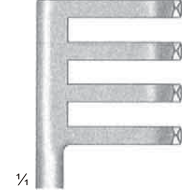

¼
17-805-20
20 cm, 8"

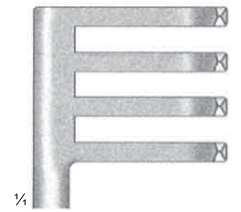

¼
17-805-26
26 cm, 10¼"

Blunt
Stumpf
Romo
Mousse
Smusso



¼
17-806-13
13 cm, 5"



¼
17-806-16
16 cm, 6¼"

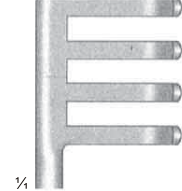

¼
17-806-20
20 cm, 8"

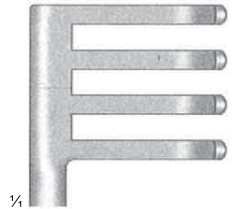

¼
17-806-26
26 cm, 10¼"

ADSON
17-805-13
17-806-26

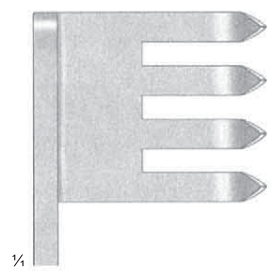
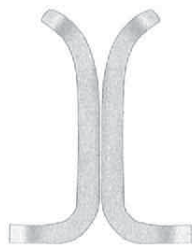

¼
17-811-01
 Sharp
 Spitz
 Agudo
 Pointu
 Acuto

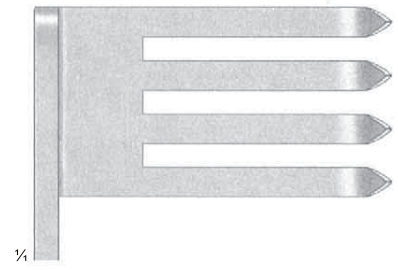

¼
17-811-02
 Sharp
 Spitz
 Agudo
 Pointu
 Acuto

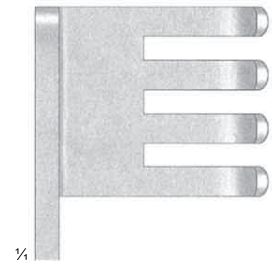

¼
17-812-01
 Blunt
 Stumpf
 Romo
 Mousse
 Smusso

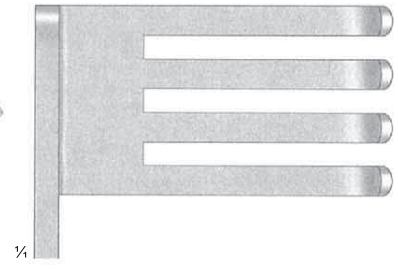

¼
17-812-02
 Blunt
 Stumpf
 Romo
 Mousse
 Smusso

BECKMANN-ADSON
 17-811-01
 17-811-02
 31 cm, 12¼"

17-812-01
17-812-02
 31 cm, 12¼"

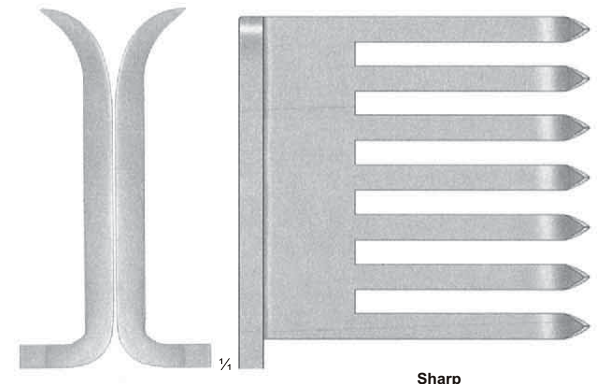

Sharp
 Spitz
 Agudo
 Pointu
 Acuto



BECKMANN-EATON
 17-815-32
 32 cm, 12½"

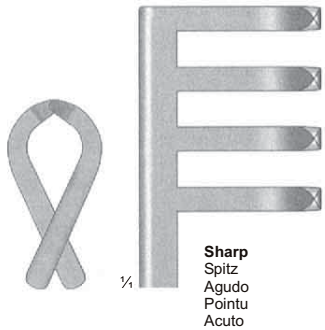

Sharp
 Spitz
 Agudo
 Pointu
 Acuto

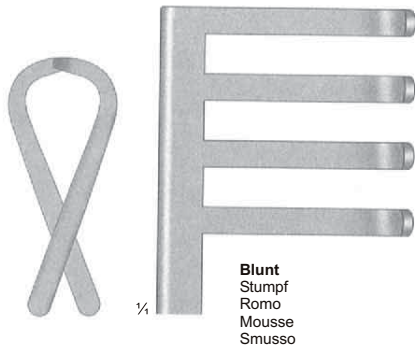

Blunt
 Stumpf
 Romo
 Mousse
 Smusso

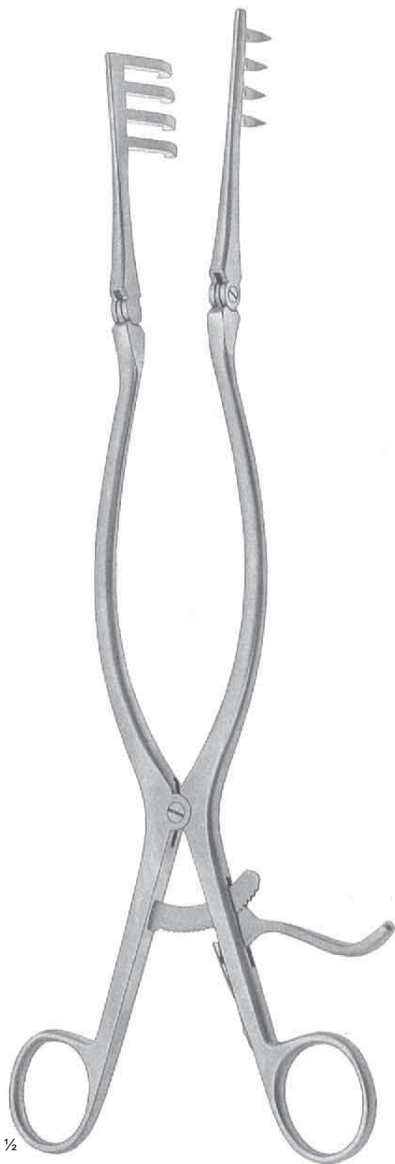

BECKMANN
 17-817-31
 31 cm, 12¼"

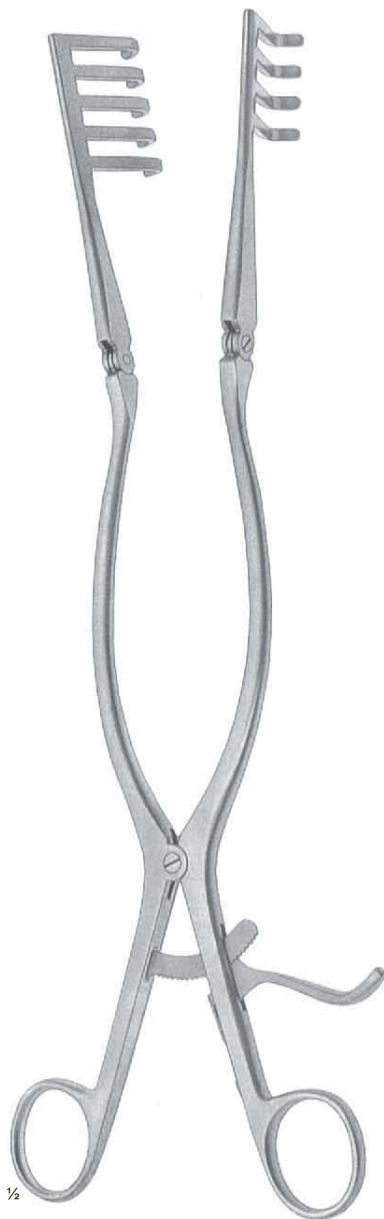

ADSON
 17-820-32
 32 cm, 12½"

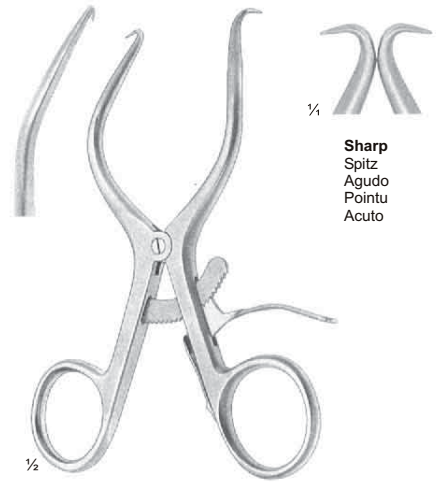

GELPI-LOKTILE
 17-825-13
 13 cm, 5"



GELPI-LOKTIE
 Sharp
 Spitz
 Agudo
 Pointu
 Acuto

17-827-09
 9 cm, 3½"
 17-827-11
 11 cm, 4½"
 17-827-13
 13 cm, 5"
 17-827-18
 18 cm, 7"

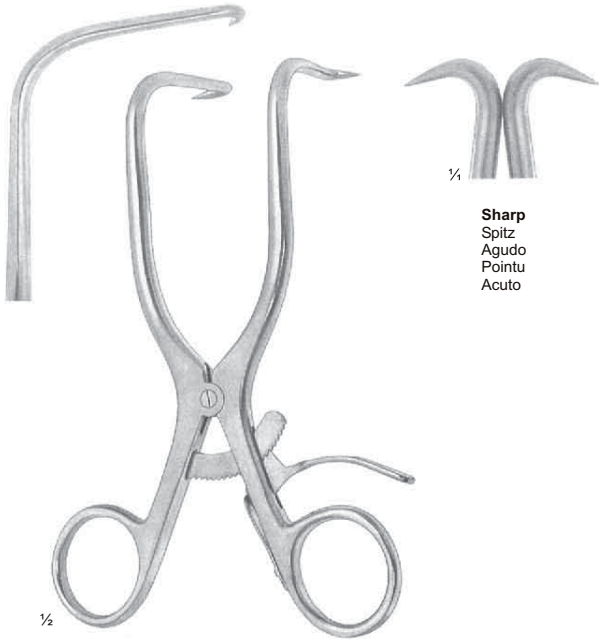

Sharp
 Spitz
 Agudo
 Pointu
 Acuto

GELPI-SEIETZ
 17-831-15
 15 cm, 6"

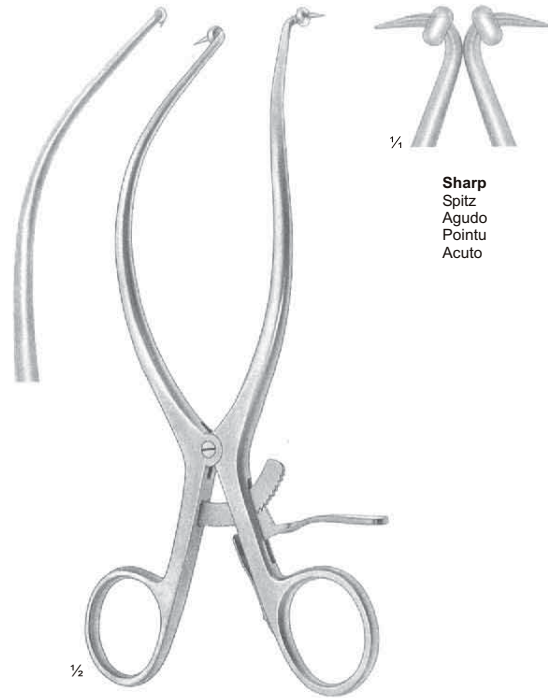

Sharp
 Spitz
 Agudo
 Pointu
 Acuto

GELPI-LOKTITE
 17-833-18
 18 cm, 7"



Sharp
 Spitz
 Agudo
 Pointu
 Acuto

JOLL(FRIEDMAN)
 17-837-15
 15,5 cm, 6"

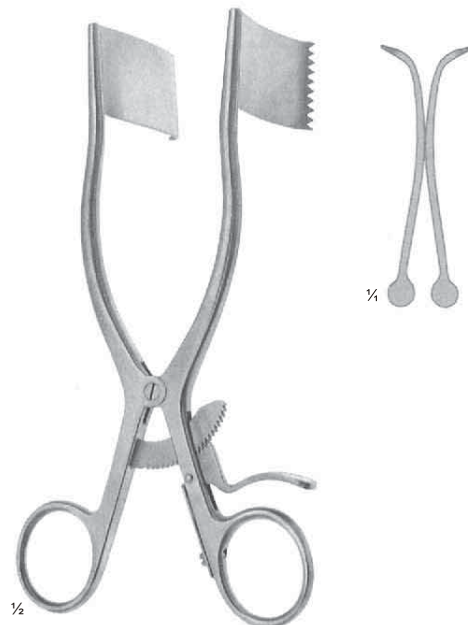

Sharp

MEYERDING
 17-839-01
 17-839-02
 17-839-03
 17-839-04
 18 cm, 7"

Lamiectomy retractors
 Laminektomie-Wundspreizer
 Separadores para laminectomia
 Ecarteurs pour laminectomie
 Divaricatori per laminectomia



Retractors for cervical spine

Wundspreizer für die cervicale Wirbesäule
Separadores para la columna cervical
Ecarteurs pour colonne cervicale
Divaricatori per colonna cervicale



CLOWARD
17-841-01
17-841-05
25 cm, 10"

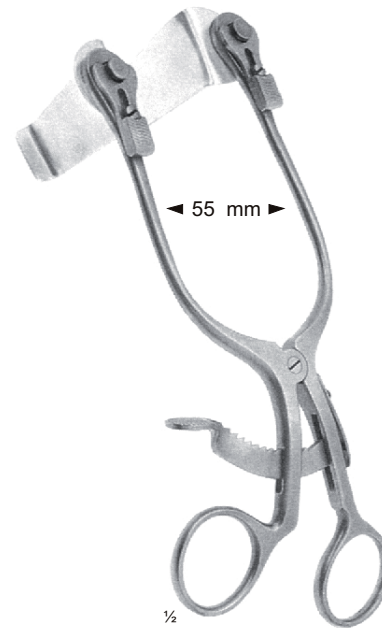
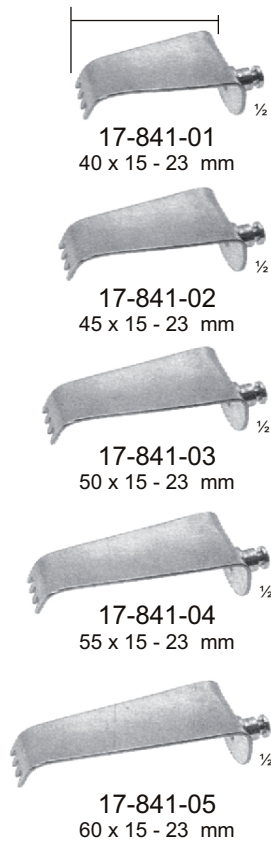

CLOWARD
17-842-01
17-842-05
16 cm, 6 1/2"

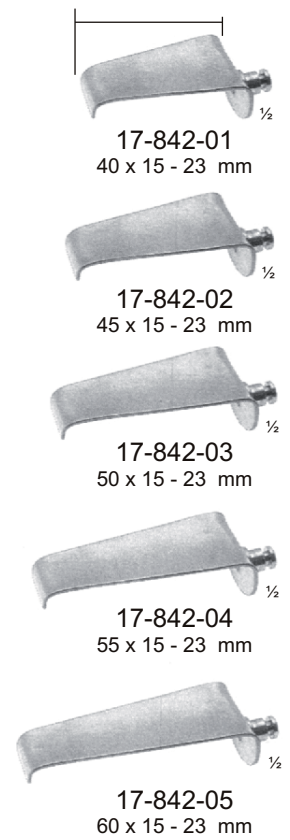

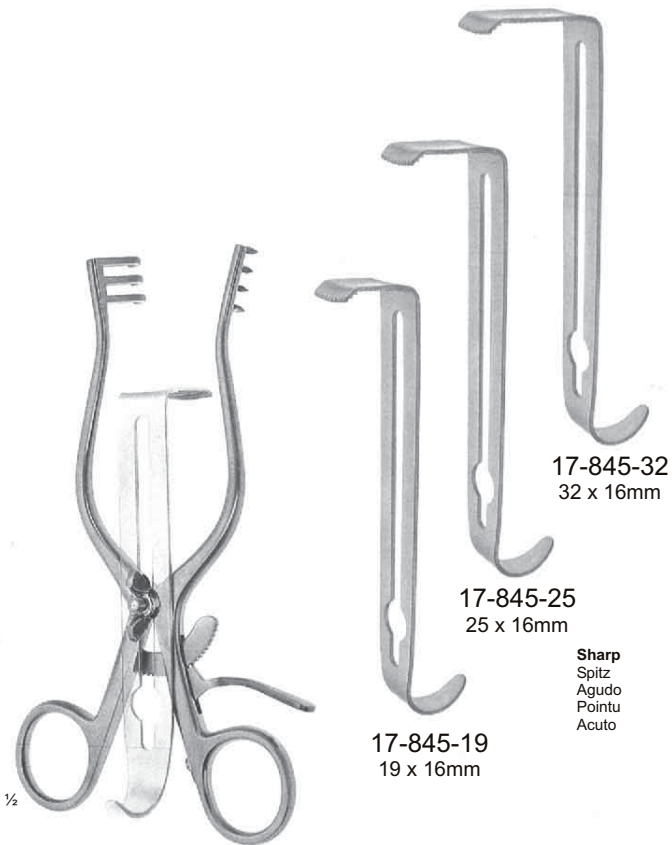

17-845-32
32 x 16mm

17-845-25
25 x 16mm

17-845-19
19 x 16mm

Sharp
Spitz
Agudo
Pointu
Acuto

HENLEY

17-845-16 17-845-19
16,5 cm, 6½" 17-845-32

Self-retaining rtractor, complete, consisting of:
17-845-16 1 Spreader with lateral valves, sharp
17-845-19 1 Central valve, serrated, 19 x 16 mm
17-845-25 1 Central valve, serrated, 25 x 16 mm
17-845-32 1 Central valve, serrated, 32 x 16 mm

Wundspreizer, komplett, bestehend aus:
17-845-16 1 Sperrer mit Seitenvalven, spitz
17-845-19 1 Gezahnten Mittelvalve 19 x 16 mm
17-845-25 1 Gezahnten Mittelvalve 25 x 16 mm
17-845-32 1 Gezahnten Mittelvalve 32 x 16 mm

Separador, completo, compuesto de:
17-845-16 1 Separador con valve laterales agudas
17-845-19 1 Valva central, dontada, 19 x 16 mm
17-845-25 1 Valva central, dentada, 25 x 16 mm
17-845-32 1 Valva central, dentada, 32 x 16 mm

Ecarteur, complet, composé de:
17-845-16 1 Ecarteur avec valves lateralés, griffes pointues
17-845-19 1 Valve central, dentelée 19 x 16 mm
17-845-25 1 Valve central, dentelée 25 x 16 mm
17-845-32 1 Valve central, dentelée 32 x 16 mm

Divaricatore, completo, compsto da:
17-845-16 1 Divaricatore con valve laterali, acuto
17-845-19 1 Valva central, dentellata, 19 x 16 mm
17-845-25 1 Valva central, dentellata, 25 x 16 mm
17-845-32 1 Valva central, dentellata, 32 x 16 mm

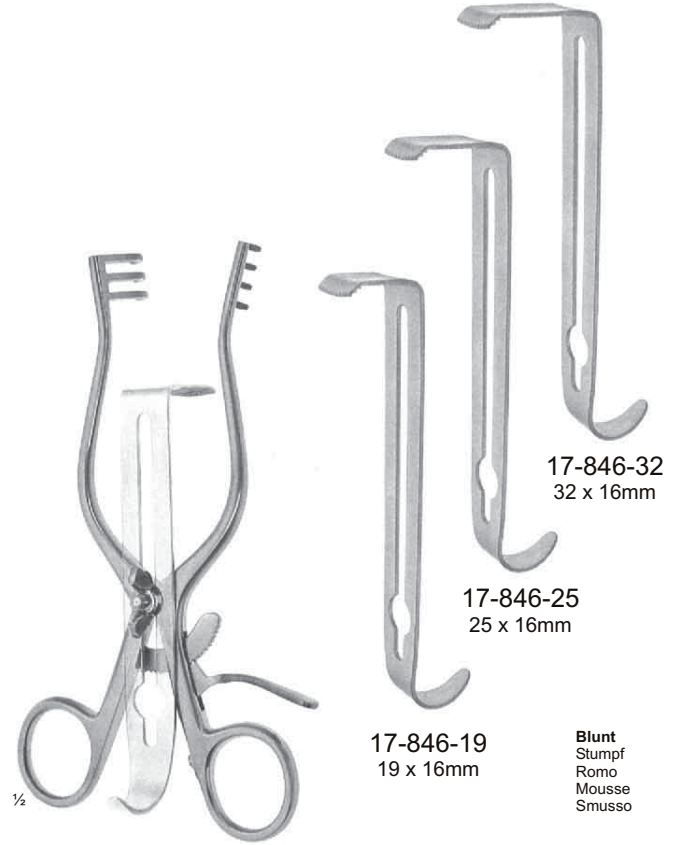

17-846-32
32 x 16mm

17-846-25
25 x 16mm

17-846-19
19 x 16mm

Blunt
Stumpf
Romo
Mousse
Smusso

HENLEY

17-846-16 17-846-19
16,5 cm, 6½" 17-846-32

Self-retaining rtractor, complete, consisting of:
17-846-16 1 Spreader with lateral valves, blunt
17-846-19 1 Central valve, serrated, 19 x 16 mm
17-846-25 1 Central valve, serrated, 25 x 16 mm
17-846-32 1 Central valve, serrated, 32 x 16 mm

Wundspreizer, komplett, bestehend aus:
17-846-16 1 Sperrer mit Seitenvalven, stumpf
17-846-19 1 Gezahnten Mittelvalve 19 x 16 mm
17-846-25 1 Gezahnten Mittelvalve 25 x 16 mm
17-846-32 1 Gezahnten Mittelvalve 32 x 16 mm

Separador, completo, compuesto de:
17-846-16 1 Separador con valve laterales romas
17-846-19 1 Valva central, dontada, 19 x 16 mm
17-846-25 1 Valva central, dentada, 25 x 16 mm
17-846-32 1 Valva central, dentada, 32 x 16 mm

Ecarteur, complet, composé de:
17-846-01 1 Ecarteur avec valves lateralés, griffes mouses
17-846-02 1 Valve central, dentelé 19 x 16 mm
17-846-03 1 Valve central, dentelé 25 x 16 mm
17-846-04 1 Valve central, dentelé 32 x 16 mm

Divaricatore, completo, compsto da:
17-846-01 1 Divaricatore con valve laterali, smusso
17-846-02 1 Valva central, dentellata, 19 x 16 mm
17-846-03 1 Valva central, dentellata, 25 x 16 mm
17-846-04 1 Valva central, dentellata, 32 x 16 mm

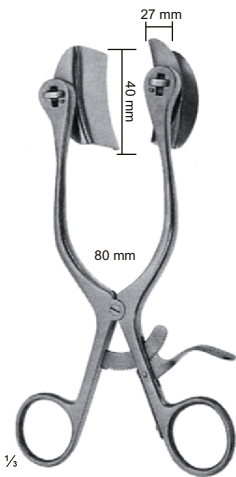

BABY-COLLIN
 17-850-18
 18 cm, 7"

Abdominal retractor, complete, consisting of:
 17-850-01 1 Spreader
 17-850-02 1 Pair lateral valves 18 x 40 mm
 17-850-03 1 Pair lateral valves 27 x 40 mm

Bauchdeckenhalter, komplett, bestehend aus:
 17-850-01 1 Sperrer
 17-850-02 1 Paar Seitenvalven 18 x 40 mm
 17-850-03 1 Paar Seitenvalven 27 x 40 mm

Separador abdominal, completo, compuesto de:
 17-850-01 1 Separador
 17-850-02 1 Par de valvas laterales 18 x 40 mm
 17-850-03 1 Par de valvas laterales 27 x 40 mm

Ecarteur abdominal, complet, composé de:
 17-850-01 1 Ecarteur
 17-850-02 1 Paire de valves latérales 18 x 40 mm
 17-850-03 1 Paire de valves latérales 27 x 40 mm

Divaricatore addominale, completo, compsto da:
 17-850-01 1 Divaricatore
 17-850-02 1 Paio di valve laterali 18 x 40 mm
 17-850-03 1 Paio di valve laterali 27 x 40 mm

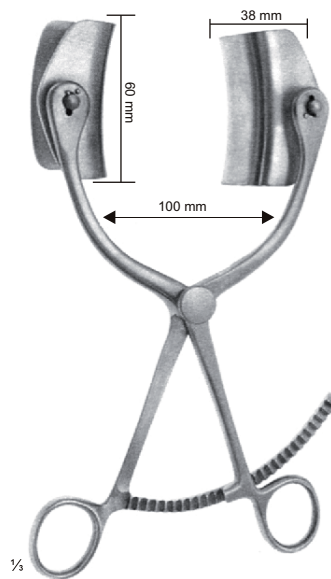

COLLIN
 17-856-23
 23 cm, 9"

Abdominal retractor, complete consisting of:
 17-856-01 1 Spreader
 17-856-02 1 Pair lateral valves 38 x 60 mm

Bauchdeckenhalter, komplett, bestehend aus:
 17-856-01 1 Sperrer
 17-856-02 1 Paar Seitenvalven 38 x 60 mm

Separador abdominal, completo, compuesto de:
 17-856-01 1 Separador
 17-856-02 1 Par de valvas laterales 38 x 60 mm

Ecarteur abdominal, complet, composé de:
 17-856-01 1 Ecarteur
 17-856-02 1 Paire de valves latérales 38 x 60 mm

Divaricatore addominale, completo, composto da:
 17-856-01 1 Divaricatore
 17-856-02 1 Paio di valve laterali 38 x 60 mm

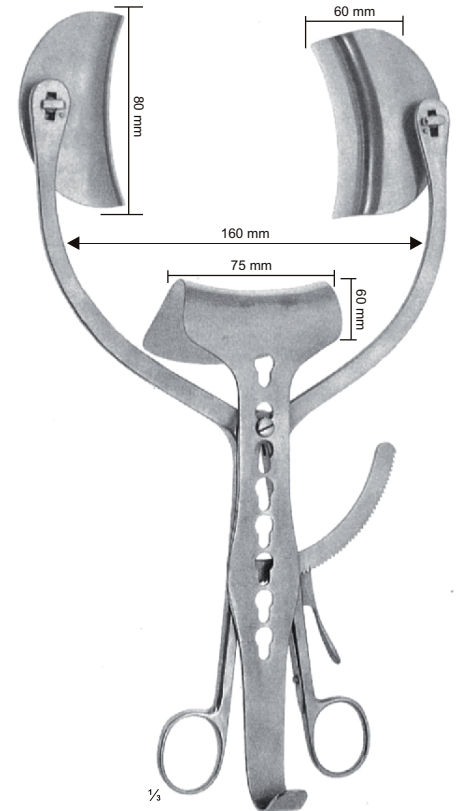

COLLIN-LOKTITE
 17-859-26
 26 cm, 10½"

Abdominal retractor, complete consisting of:
 17-859-01 1 Spreader
 17-859-02 1 Pair lateral valves 60 x 80 mm
 17-859-03 1 Mittelvalve 60 x 75 mm

Bauchdeckenhalter, komplett, bestehend aus:
 17-859-01 1 Sperrer
 17-859-02 1 Paar Seitenvalven 60 x 80 mm
 17-859-03 1 Central valve 60 x 75 mm

Separador abdominal, completo, compuesto de:
 17-859-01 1 Separador
 17-859-02 1 Par de valvas laterales 60 x 80 mm
 17-859-03 1 Valva central 60 x 75 mm

Ecarteur abdominal, complet, composé de:
 17-859-01 1 Ecarteur
 17-859-02 1 Paire de valves latérales 60 x 80 mm
 17-859-03 1 Valva centrale 60 x 75 mm

Divaricatore addominale, completo, composto da:
 17-859-01 1 Divaricatore
 17-859-02 1 Paio di valve laterali 60 x 80 mm
 17-859-03 1 Valva centrale 60 x 75 mm

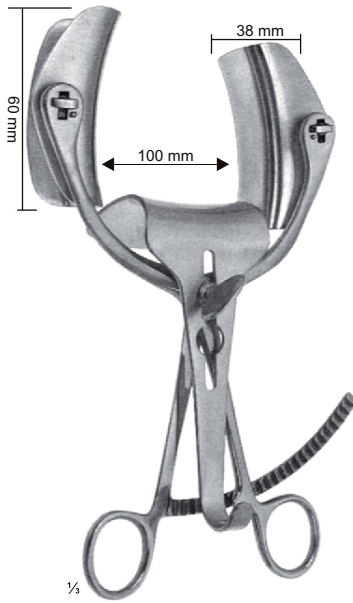

COLLIN
 17-860-25
 25 cm, 9½"

Abdominal retractor, complete, consisting of:
 17-860-01 1 Spreader
 17-860-02 1 Pair lateral valves 38 x 80 mm
 17-860-03 1 Pair lateral valves 55 x 55 mm

Bauchdeckenhalter, komplett, bestehend aus:
 17-860-01 1 Sperrer
 17-860-02 1 Paar Seitenvälven 38 x 80 mm
 17-860-03 1 Paar Seitenvälven 55 x 55 mm

Separador abdominal, completo, compuesto de:
 17-860-01 1 Separador
 17-860-02 1 Par de valvas laterales 38 x 80 mm
 17-860-03 1 Par de valvas laterales 55 x 55 mm

Ecarteur abdominal, complet, composé de:
 17-860-01 1 Ecarteur
 17-860-02 1 Paire de valves latérales 38 x 80 mm
 17-860-03 1 Paire de valves latérales 55 x 55 mm

Divaricatore addominale, completo, composto da:
 17-860-01 1 Divaricatore
 17-860-02 1 Paio di valve laterali 38 x 80 mm
 17-860-03 1 Paio di valve laterali 55 x 55 mm

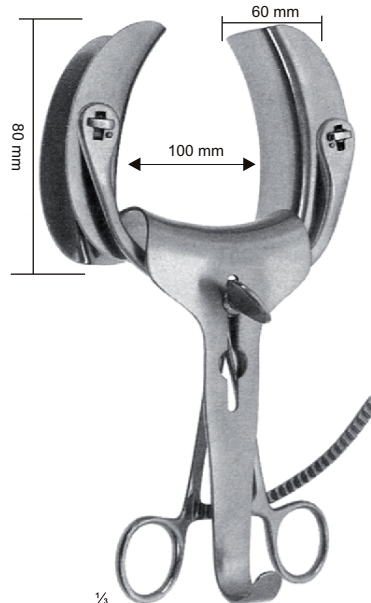

COLLIN
 17-862-26
 26 cm, 10¼"

Abdominal retractor, complete, consisting of:
 17-862-01 1 Spreader
 17-862-02 1 Pair lateral valves 40 x 100 mm
 17-862-03 1 Pair lateral valves 55 x 75 mm

Bauchdeckenhalter, komplett, bestehend aus:
 17-862-01 1 Sperrer
 17-862-02 1 Paar Seitenvälven 40 x 100 mm
 17-862-03 1 Paar Seitenvälven 55 x 75 mm

Separador abdominal, completo, compuesto de:
 17-862-01 1 Separador
 17-862-02 1 Par de valvas laterales 40 x 100 mm
 17-862-03 1 Par de valvas laterales 55 x 75 mm

Ecarteur abdominal, complet, composé de:
 17-862-01 1 Ecarteur
 17-862-02 1 Paire de valves latérales 40 x 100 mm
 17-862-03 1 Paire de valves latérales 55 x 75 mm

Divaricatore addominale, completo, composto da:
 17-862-01 1 Divaricatore
 17-862-02 1 Paio di valve laterali 40 x 100 mm
 17-862-03 1 Paio di valve laterali 55 x 75 mm



RICARD
 17-870-28
 28 cm, 11"
 17-870-30
 30 cm, 12"

Abdominal retractor, complete consisting of:
 17-870-01 1 Spreader
 17-870-02 1 Pair lateral valves 60 x 80 mm
 17-870-03 1 Mittelvalve 55 x 70 mm

Bauchdeckenhalter, komplett, bestehend aus:
 17-870-01 1 Sperrer
 17-870-02 1 Paar Seitenvälven 60 x 80 mm
 17-870-03 1 Central valve 55 x 70 mm

Separador abdominal, completo, compuesto de:
 17-870-01 1 Separador
 17-870-02 1 Par de valvas laterales 60 x 80 mm
 17-870-03 1 Valva central 55 x 70 mm

Ecarteur abdominal, complet, composé de:
 17-870-01 1 Ecarteur
 17-870-02 1 Paire de valves latérales 60 x 80 mm
 17-870-03 1 Valva centrale 55 x 70 mm

Divaricatore addominale, completo, composto de:P
 17-870-01 1 Divaricatore
 17-870-02 1 Paio di valve laterali 60 x 80 mm
 17-870-03 1 Valva centrale 55 x 70 mm

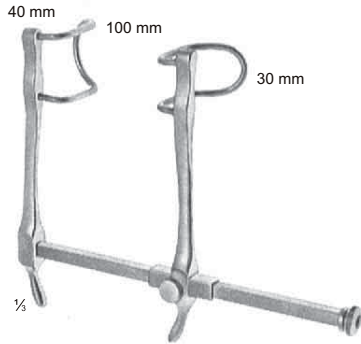

GOSSET-BABY
 17-880-00

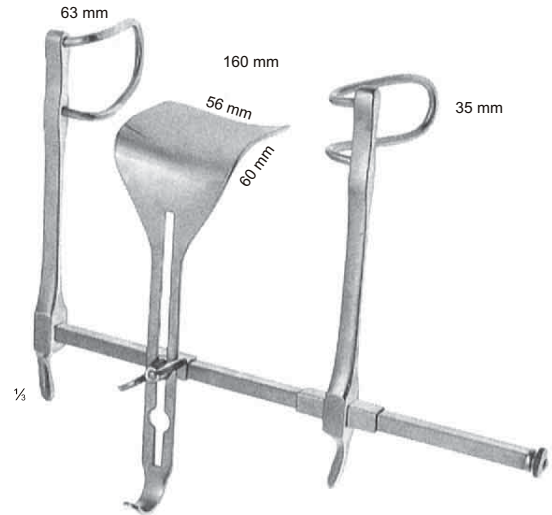

GOSSET
 17-884-00
 Set , Setz , Juego , Jeu , Serie

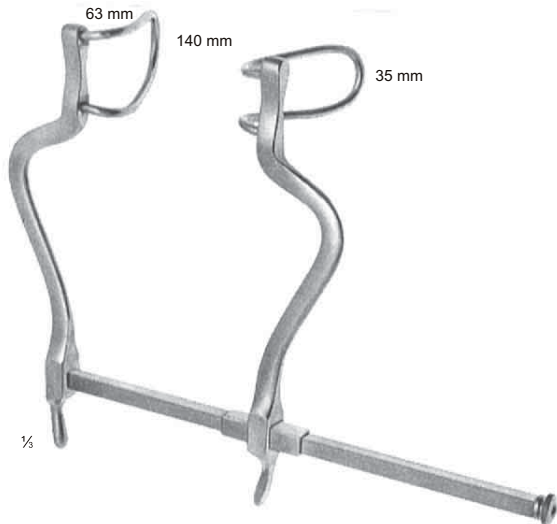

GOSSET
 17-882-00

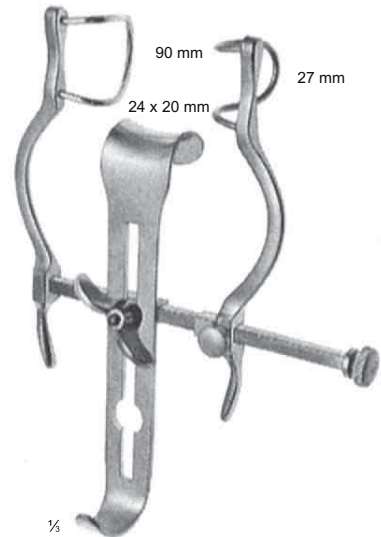

BALFOUR-BABY
 17-890-00
 Set , Setz , Juego , Jeu , Serie



BALFOUR
 17-892-00 180mm
 17-892-01 200mm
 Set , Setz , Juego , Jeu , Serie

1/3

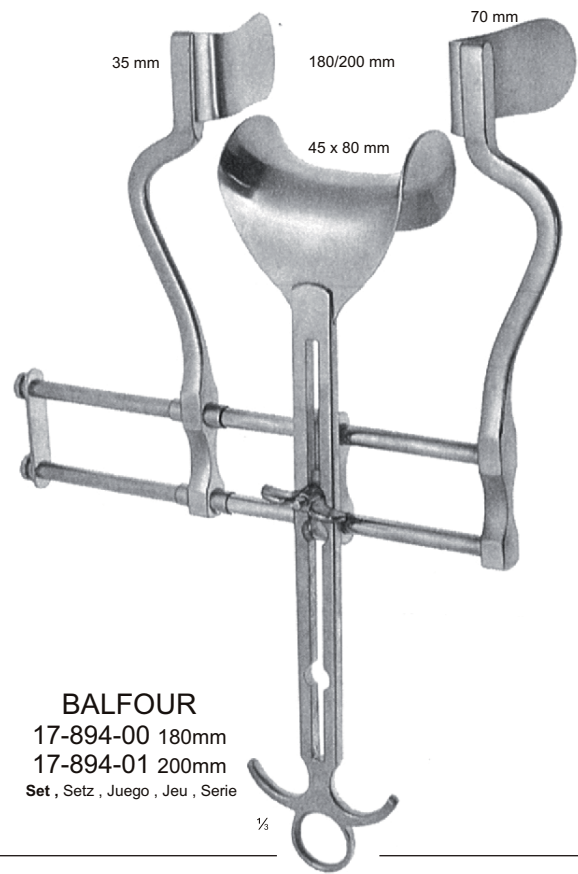

BALFOUR
 17-894-00 180mm
 17-894-01 200mm
 Set , Setz , Juego , Jeu , Serie

1/3

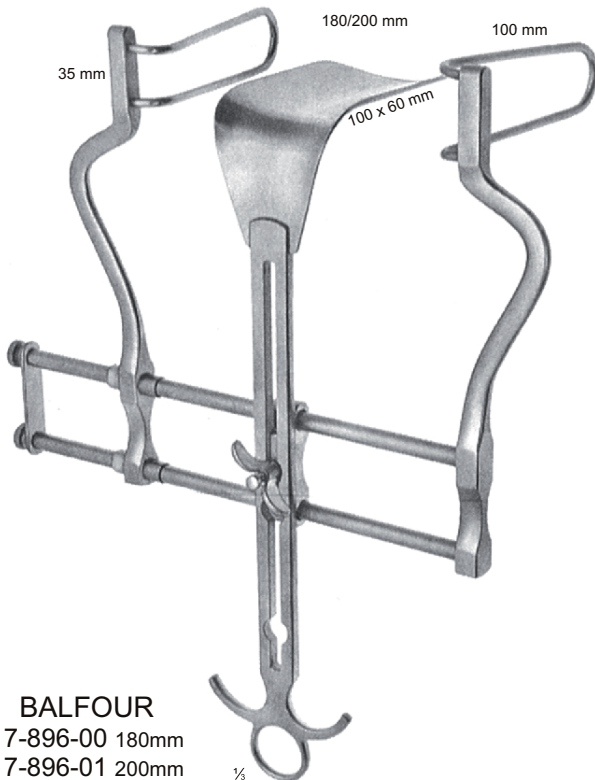

BALFOUR
 17-896-00 180mm
 17-896-01 200mm
 Set , Setz , Juego , Jeu , Serie

1/3

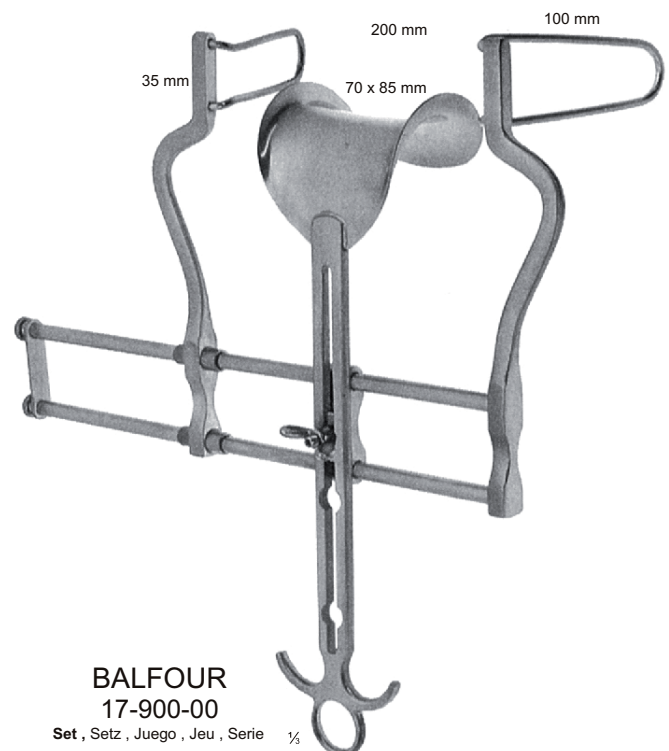

BALFOUR
 17-900-00
 Set , Setz , Juego , Jeu , Serie

1/3

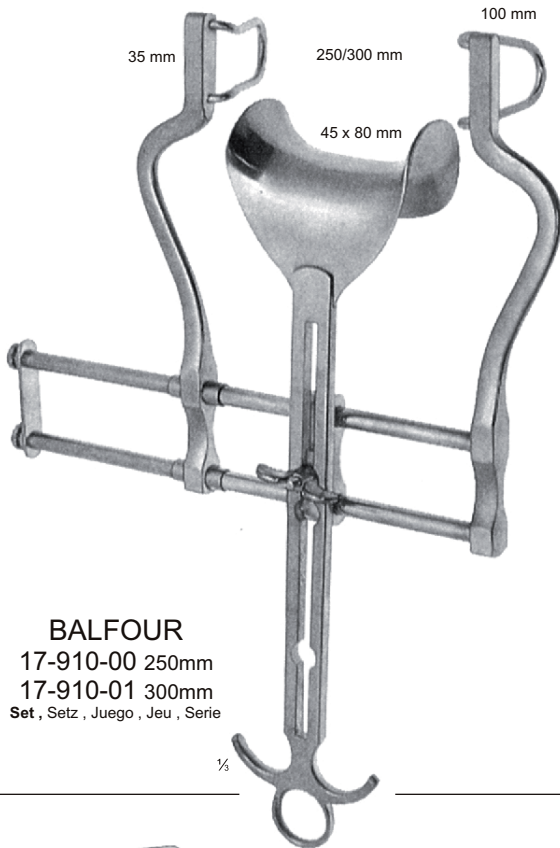

BALFOUR
 17-910-00 250mm
 17-910-01 300mm
 Set , Setz , Juego , Jeu , Serie

1/2

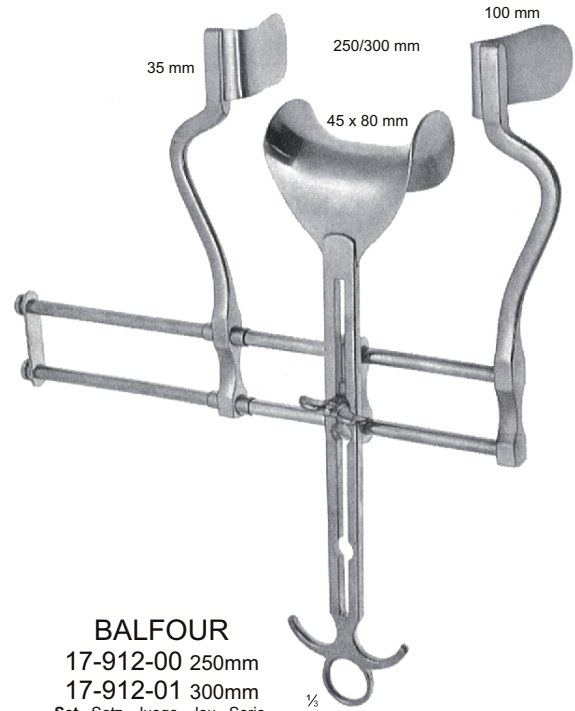

BALFOUR
 17-912-00 250mm
 17-912-01 300mm
 Set , Setz , Juego , Jeu , Serie

1/2



BALFOUR-US TYPE
 17-920-00

1/2

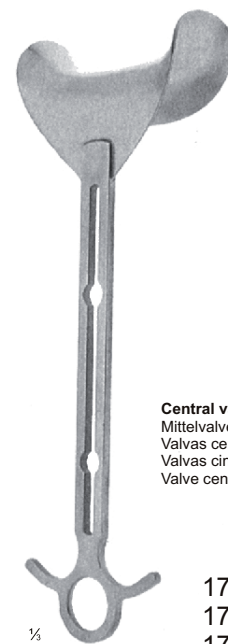

Central valves, for abdominal retractors
 Mittelvalven für Bauchdeckenhalter
 Valvas centrales, para separadores abdominales
 Valvas cintrales, pour écarteurs abdominaux
 Valve centrali, per divaricatori addominali

BALFOUR
 17-914-01 45 x 80 mm
 17-914-02 70 x 85 mm
 17-914-03 45 x 90 mm

1/2



Abdominal Retractors
 Bauchdeckenhalter
 Separadores abdominales
 Ecarteurs abdominaux
 Divaricatori addominali



017



ROCHARD
17-930-01

Mounting frame for fastening to both sides of the lateral bare 25 x 10 mm of the operating tables, can be dismantled for sterilization

Befestigungsgestell mit beidseitiger Fixierung an den seitenschiene 25 x 10 mm der OP-Tische, zur Sterilisation zerigbar

Bastidor para la fijación a las ambas barras laterales 25 x 10 mm de las mesas de operación, plegable para la esterilización

Cadre se fixant aux barres latérales 25 x 10 mm de chaques côtés de la table d'opération, pliable pour stérilisation

Telaio di supporto per il fissaggio alla barra laterale 25 x 10 mm del tavolo operatorio può essere smontato per la sterlizzazione



ROCHARD
17-938-19
19,5 cm, 7 3/4"

Fixation device for 17-966-01_17-966-05
 Fixiervorrichtung für 17-966-01_17-966-05
 Dispositivo de fijación para 17-966-01_17-966-05
 Compas articulé pour 17-966-01_17-966-05
 Dispositivo di fissaggio per 17-966-01_17-966-05

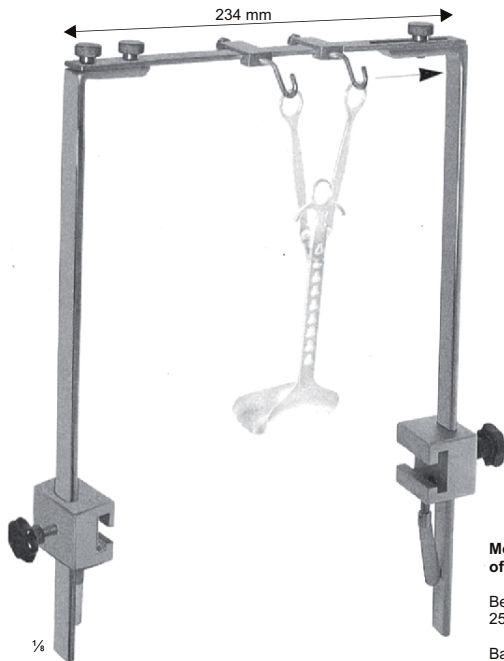

ROCHARD
17-930-02

Mounting frame for fastening to the lateral bare 25 x 10 mm of the operating tables, can be dismantled for sterilization

Befestigungsgestell mit beidseitiger Fixierung an den seitenschiene 25 x 10 mm der OP-Tische, zur Sterilisation zerlegbar

Bastidor para la fijación a las ambas laterales 25 x 10 mm de las mesas de operación, plegable para la esterilización

Cadre se fixant aux barres latérales 25 x 10 mm de chaques côtés de la table d'opération, pliable pour stérilisation

Telaio di per il fissaggio alla barra laterale 25 x 10 mm del tavolo operatorio può essere smontato per la sterlizzazione



ROCHARD
17-936-01 50 x 90 mm
17-936-02 50 x 105 mm
17-936-03 50 x 120 mm
17-936-04 50 x 135 mm
17-936-05 50 x 155 mm
29 cm, 11 1/2"

Abdominal retractors
 Bauchdeckenhaken
 Separadores abdominales
 Ecarteur abdominal
 Divaricatore addominali

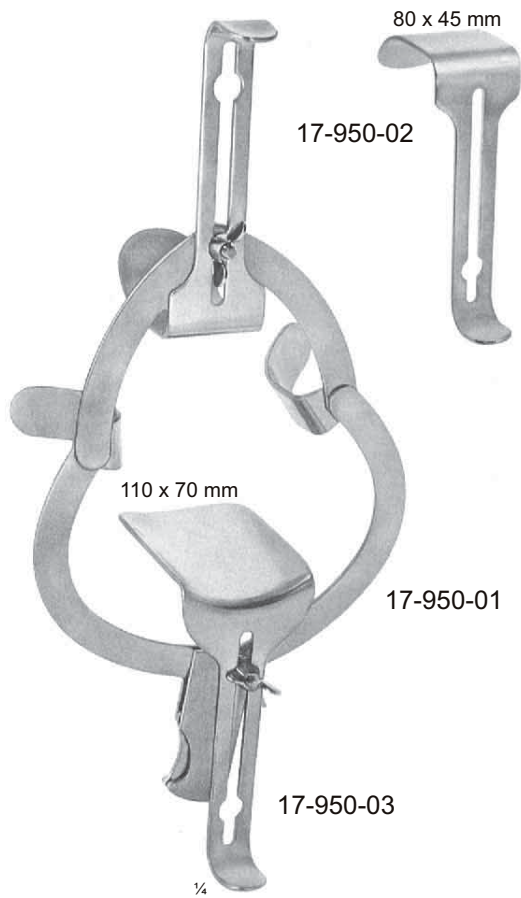

O'SULLIVAN-O'CONNOR
 17-950-00

Abdominal ractractor, complete, consisting of:
 17-950-01 1 Frame
 17-950-02 2 Valves 80 x 45 mm
 17-950-03 1 Valve 110 x 70 mm

Bauchdeckenhalter, komplett, bestehend aus:
 17-950-01 1 Rahmen
 17-950-02 2 Ventile 80 x 45 mm
 17-950-03 1 Valve 110 x 70 mm

Separador abdominal, completo, compuesto de:
 17-950-01 1 Cuadro
 17-950-02 2 Valvas 80 x 45 mm
 17-950-03 1 Valva 110 x 70 mm

Ecarteur abdominal, complet, composé de:
 17-950-01 1 Cadre
 17-950-02 2 Valves 80 x 45 mm
 17-950-03 1 Valve 110 x 70 mm

Divaricatore addominale, completo, compsto da:
 17-950-01 1 Telaio
 17-950-02 2 Valve 80 x 45 mm
 17-950-03 1 Valva 110 x 70 mm

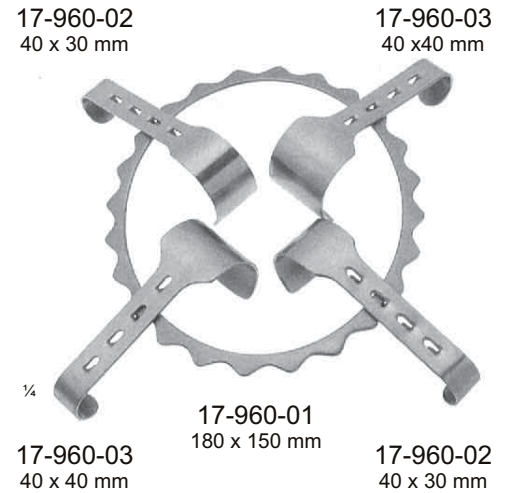

DENIS-BROWNE

17-960-00 180 x 150 mm
 17-960-01 255 x 180 mm

Abdominal ractractor, complete, consisting of:
 17-925-01 1 Frame 180 x 150 mm
 17-925-02 2 Valves 40 x 30 mm
 17-925-03 1 Valves 40 x 40 mm

Bauchdeckenhalter, komplett, bestehend aus:
 17-925-01 1 Rahmen 180 x 150 mm
 17-925-02 2 Ventile 40 x 30 mm
 17-925-03 1 Valven 40 x 40 mm

Separador abdominal, completo, compuesto de:
 17-925-01 1 Cuadro 180 x 150 mm
 17-925-02 2 Valvas 40 x 30 mm
 17-925-03 1 Valvas 40 x 40 mm

Ecarteur abdominal, complet, composé de:
 17-925-01 1 Cadre 180 x 150 mm
 17-925-02 2 Valves 40 x 30 mm
 17-925-03 1 Valvas 40 x 40 mm

Divaricatore addominale, completo, composto da:
 17-925-01 1 Telaio 180 x 150 mm
 17-925-02 2 Valve 40 x 30 mm
 17-925-03 1 Valve 40 x 40 mm

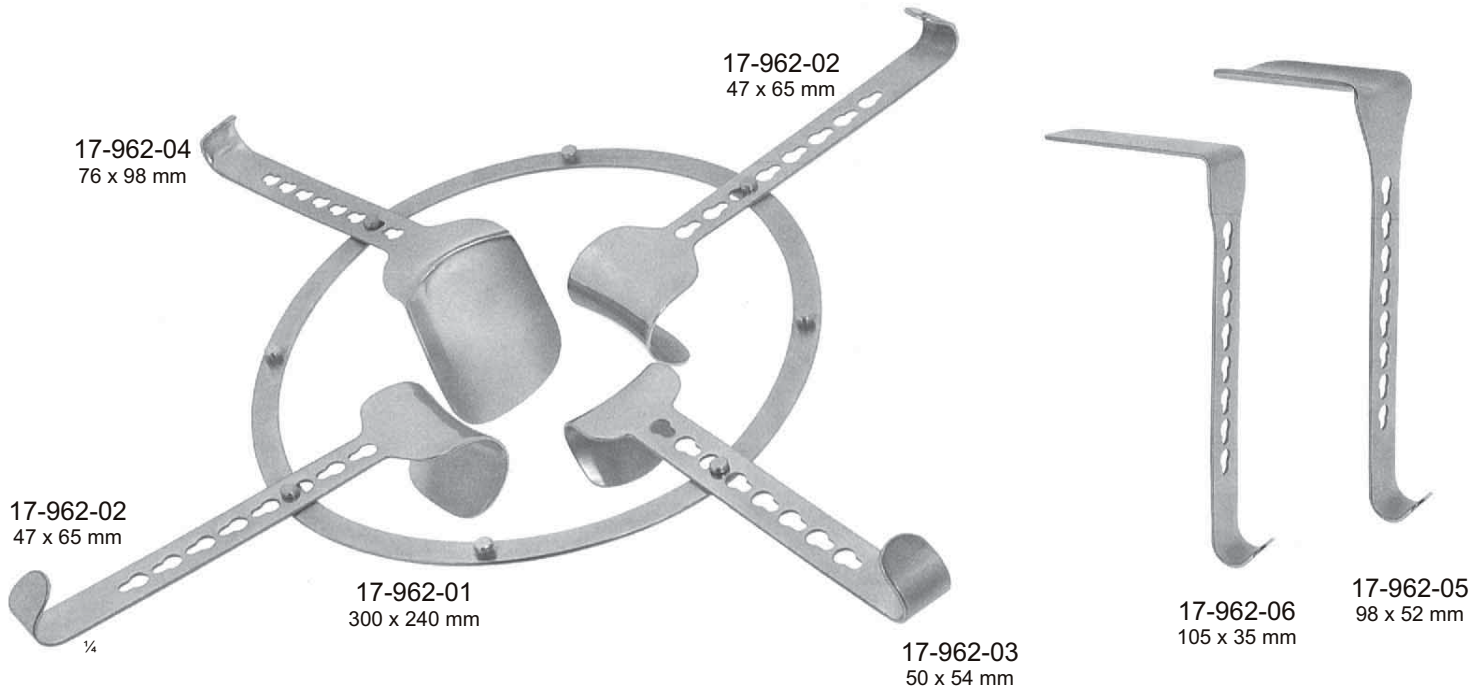

**SEMM
 17-962-00**

Set , Setz , Juego , Jeu , Serie

Abdominal retractor, complete, consisting of:
 17-962-01 1 Frame 275 x 250 mm
 17-962-02 2 Valves 47 x 65 mm
 17-962-03 1 Valve for bladder 50 x 54 mm
 17-962-04 1 Valve for intestine 76 x 98 mm
 17-962-05 1 Valve for intestine 98 x 52 mm
 17-962-06 1 Valve 105 x 35 mm

Ecarteur abdominal, complet, composé de:
 17-962-01 1 Cadre 275 x 250 mm
 17-962-02 2 Valves 47 x 65 mm
 17-962-03 1 Valve pour vessie 50 x 54 mm
 17-962-04 1 Valve pour intestin 76 x 98 mm
 17-962-05 1 Valve pour intestin 98 x 52 mm
 17-962-06 1 Valve 105 x 35 mm

Bauchdeckenhalter, komplett, bestehend aus:
 17-962-01 1 Rahmen 275 x 250 mm
 17-962-02 2 Valven 47 x 65 mm
 17-962-03 1 Valve für die Blase 50 x 54 mm
 17-962-04 1 Valve für den Darm 76 x 98 mm
 17-962-05 1 Valve für den Darm 98 x 52 mm
 17-962-06 1 Valve 105 x 35 mm

Divaricatore addominale, completo, composto da:
 17-962-01 1 Telaio 275 x 250 mm
 17-962-02 1 Valva 47 x 65 mm
 17-962-03 1 Valva per vescica 50 x 54 mm
 17-962-04 1 Valva per intestino 76 x 98 mm
 17-962-05 1 Valva per intestino 98 x 52 mm
 17-962-06 1 Valva 105 x 35 mm

Separador abdominal, completo, compuesto de:
 17-962-01 1 Cuadro 275 x 250 mm
 17-962-02 2 Valvas 47 x 65 mm
 17-962-03 1 Valva para vejiga 50 x 54 mm
 17-962-04 1 Valva para intestino 76 x 98 mm
 17-962-05 1 Valva para intestino 98 x 52 mm
 17-962-06 1 Valva 105 x 35 mm

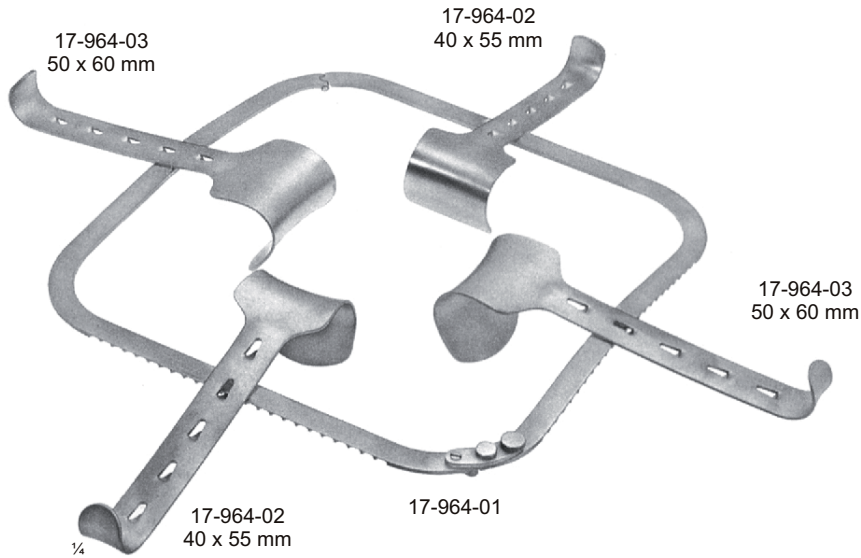

KIRSCHNER
17-964-00

Set , Setz , Juego , Jeu , Serie

Abdominal Retractor, complete, consisting of:
17-964-01 1 Folding frame 255 x 255 mm
17-964-02 2 Valves 40 x 55 mm
17-964-03 2 Valves 50 x 60 mm

Bauchdeckenhalter, komplett, bestehend aus:
 17-964-01 1 zusammenlegbarer Rahmen 255 x 255 mm
 17-964-02 2 Ventile 40 x 55 mm
 17-964-03 2 Ventile 50 x 60 mm

Separador abdominal, completo, compuesto de:
 17-964-01 1 Cuadro plegable 255 x 255 mm
 17-964-02 2 Valvas 40 x 55 mm
 17-964-03 2 Valvas 50 x 60 mm

Ecarteur abdominal, complet, composé de:
 17-964-01 1 Cadre pliant 255 x 255 mm
 17-964-02 2 Valves 40 x 55 mm
 17-964-03 2 Valves 50 x 60 mm

Divaricatore addominale, completo, composto da:
 17-964-01 1 Telaio pieghevole 255 x 255 mm
 17-964-02 2 Valve 40 x 55 mm
 17-964-03 2 Valve 50 x 60 mm

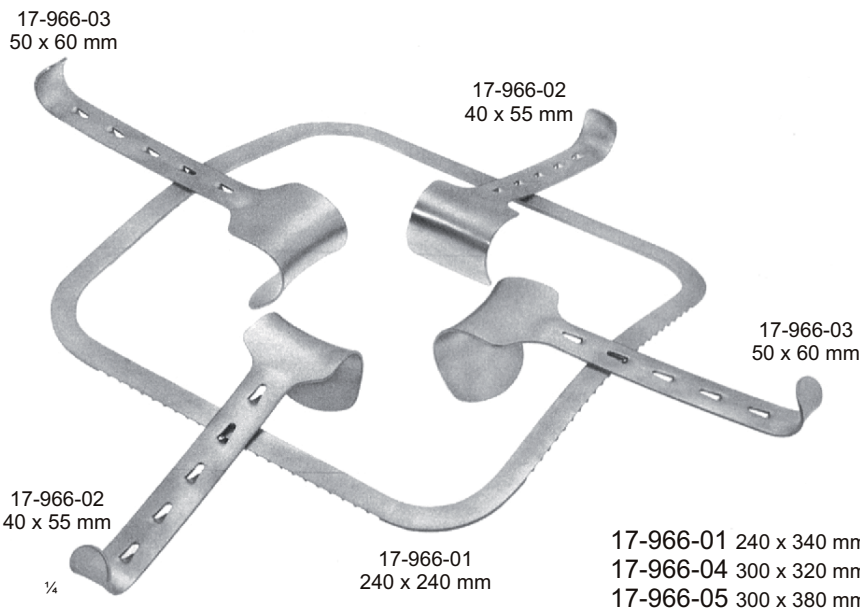

KIRSCHNER
17-966-02

Set , Setz , Juego , Jeu , Serie

Abdominal Retractor, complete, consisting of:
17-966-01 1 Fixed frame 240 x 240 mm
17-966-02 2 Valves 40 x 55 mm
17-966-03 2 Valves 50 x 60 mm

Bauchdeckenhalter, komplett, bestehend aus:
 17-966-01 1 starrer Rahmen 240 x 240 mm
 17-966-02 2 Ventile 40 x 55 mm
 17-966-03 2 Ventile 50 x 60 mm

Separador abdominal, completo, compuesto de:
 17-966-01 1 Cuadro fijo 240 x 240 mm
 17-966-02 2 Valvas 40 x 55 mm
 17-966-03 2 Valvas 50 x 60 mm

Ecarteur abdominal, complet, composé de:
 17-966-01 1 Cadre fixe 240 x 240 mm
 17-966-02 2 Valve 40 x 55 mm
 17-966-03 2 Valve 50 x 60 mm

Divaricatore addominale, completo, composto da:
 17-966-01 1 Telaio pieghevole 240 x 240 mm
 17-966-02 2 Valve 40 x 55 mm
 17-966-03 2 Valve 50 x 60 mm

17-966-01 240 x 340 mm
17-966-04 300 x 320 mm
17-966-05 300 x 380 mm

Fixed frames
 Starre Rahmen
 Cuadros fijos
 Cadres fixe
 Telaio fisso

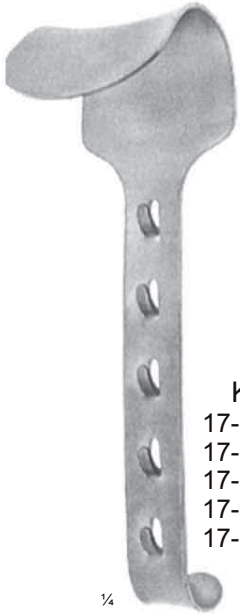

¼

KIRSCHNER

- 17-970-01 40x55mm
- 17-970-02 50x65mm
- 17-970-03 60x85mm
- 17-970-04 78x65mm
- 17-970-05 80x90mm



¼

**KIRSCHNER
BALFOUR**

- 17-972-01
- 17-972-02
- 78x65mm
- 80x90mm



¼

STANDARD

- 17-974-01
- 17-974-02
- 17-974-03
- 40x55mm
- 50x65mm
- 60x85mm



½

KIRSCHNER

- 17-976-01
- 17-976-02
- 98x50mm
- 105x35mm

Laminectomy Retractors
 Laminektomie-Spreizer
 Separadores para laminectomia
 Ecarteurs pour laminectomie
 Divaricatori per laminectomia

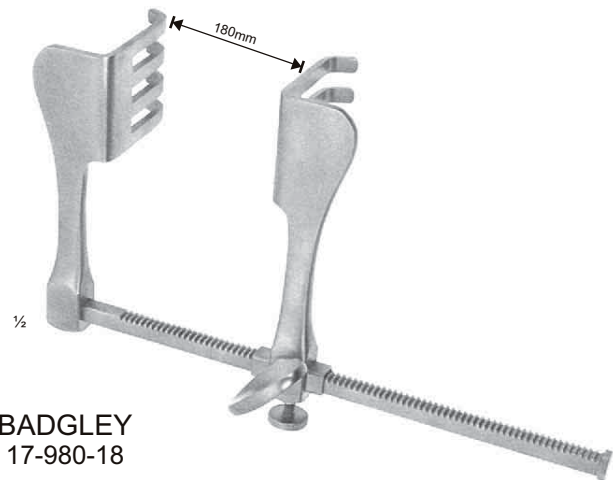

½

**BADGLEY
17-980-18**

- Self-retaining retractor, lateral velvcs 52 x 22 mm**
- Wundspreizer, Seitenvalvaen 52 x 22 mm
- Separador, valvas laterales 52 x 22 mm
- Ecarteur, valves laterales 52 x 22 mm
- Divaricatore, valve laterali 52 x 22 mm



Abdominal Retractors
Bauchdeckenhalter
Separadores abdominales
Ecarteurs abdominaux
Divaricatori addominali



017

Self-retaining retractor, complete, consisting of:
17-982-01 1 Frame
17-982-01 1 Hook 50mm
17-982-03 1 Lateral valve 64 x 25 mm

Wundspreizer, komplett, bestehend aus:
17-982-01 1 Rahmen
17-982-01 1 Haken 50 mm
17-982-03 1 Seitenvlve 64 x 25 mm

Separador, completo, compuesto de:
17-982-01 1 Cuadro
17-982-01 1 Gancho 50 mm
17-982-03 1 Valva lateral 64 x 25 mm

Ecarteur, complet, composé de:
17-982-01 1 Cadre
17-982-01 1 Crochet 50 mm
17-982-03 1 Valve latérale 64 x 25 mm

Divaricatore, completo, composto da:
17-982-01 1 Telaio
17-982-01 1 Divaricatore 50 mm
17-982-03 1 Valva laterale 64 x 25 mm

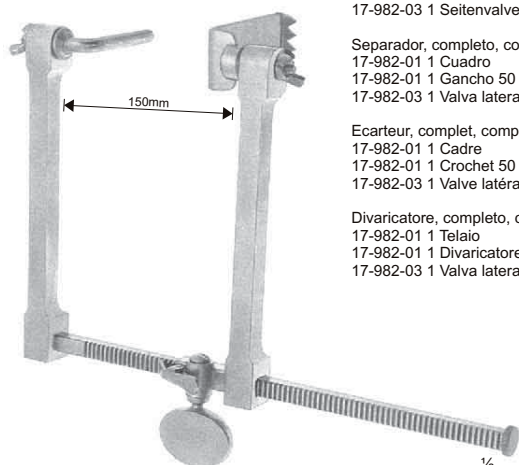

SCOVILLE
17-982-00



SCOVILLE
17-982-01 50 mm
17-982-02 70 mm

Hooks for self-retaining retractors 17-982-00 and 17-984-00

Haken für Wundspreizer
17-982-00 und 17-984-00

Ganchos para separadores
17-982-00 y 17-984-00

Crochet pour écarteurs
17-982-00 et 17-984-00

Gancio per divaricatori
17-982-00 e 17-984-00



SCOVILLE
17-982-03 64 X 25 mm
17-982-04 64 X 50 mm
17-982-05 88 X 25 mm

Lateral valves for self-retaining retractors 17-982-00 and 17-984-00

Seitenvlven für Wundspreizer
17-982-00 und 17-984-00

Valvas laterales para separadores
17-982-00 y 17-984-00

Valves latérales pour écarteurs
17-982-00 et 17-984-00

Valve laterali per divaricatori
17-982-00 et 17-984-00

With articulated arms
Mit Gelenkarmen
Còn brazos articulados
Avec bras, articulés
Con braccio articolato

Self-retaining retractor, complete, consisting of:
17-984-01 1 Frame
17-982-01 1 Hook 50mm
17-982-03 1 Lateral valve 64 x 25 mm

Wundspreizer, komplett, bestehend aus:
17-984-01 1 Rahmen
17-982-01 1 Haken 50 mm
17-982-03 1 Seitenvlve 64 x 25 mm

Separador, completo, compuesto de:
17-984-01 1 Cuadro
17-982-01 1 Gancho 50 mm
17-982-03 1 Valva lateral 64 x 25 mm

Ecarteur, complet, composé de:
17-984-01 1 Cadre
17-982-01 1 Crochet 50mm
17-982-03 1 Valve latérale 64 x 25 mm

Divaricatore, completo, composto da:
17-984-01 1 Telaio
17-982-01 1 Divaricatore 50 mm
17-982-03 1 Valva laterale 64 x 25 mm

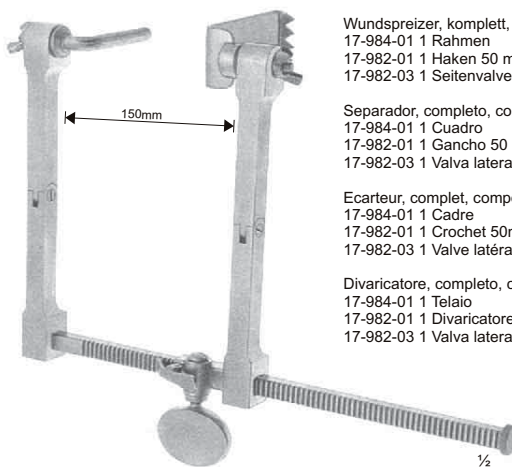

SCOVILLE-HAVERFIELD
17-984-00



SCOVILLE
17-982-06 41 X 38 mm
17-982-07 67 X 44 mm

Lateral valves for self-retaining retractors 17-982-12 and 17-984-00

Seitenvlven für Wundspreizer
17-98-12 und 17-984-00

Valvas laterales para separadores
17-982-12 y 17-984-00

Valves latérales pour écarteurs
17-982-12 et 17-984-00

Valve laterali per divaricatori
17-982-12 e 17-984-00



TAYLOR
17-982-08 48 X 50 mm
17-982-09 64 X 50 mm
17-982-10 64 X 64 mm
17-982-11 80 X 57 mm

Lateral valves for self-retaining retractors 17-982-00 and 17-984-00

Seitenvlven für Wundspreizer
17-982-00 und 17-984-00

Valvas laterales para separadores
17-982-00 y 17-984-00

Valves latérales pour écarteurs
17-982-00 et 17-984-00

Valve laterali per divaricatori
17-982-00 e 17-984-00

