

017



**Retractors**  
**Wundhaken**  
**Separadores**  
**Ecarteurs**  
**Divaricatori**

### Wound and Nerve Hooks

Wund- und Hauthäkchen (Nervhäkchen)  
 Ganchos y ganchitos para nervios  
 Ecarteurs très fins et crochets à nerfs  
 Divaricatori finini (Uncini per nervi)

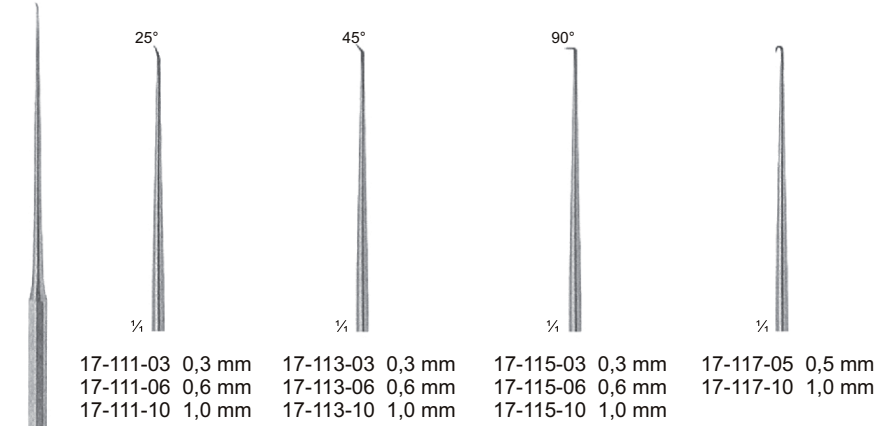

17-111-03 0,3 mm	17-113-03 0,3 mm	17-115-03 0,3 mm	17-117-05 0,5 mm
17-111-06 0,6 mm	17-113-06 0,6 mm	17-115-06 0,6 mm	17-117-10 1,0 mm
17-111-10 1,0 mm	17-113-10 1,0 mm	17-115-10 1,0 mm	

#### SHAMBAUGH

17-111-03  
 17-117-10  
 15,5 cm, 6"

**Hooks for micro surgery**  
 Häkchen für die mikrochirurgie  
 Ganchos para la microcirugía  
 Crochets à microchirurgie  
 Crochet per microchirurgia

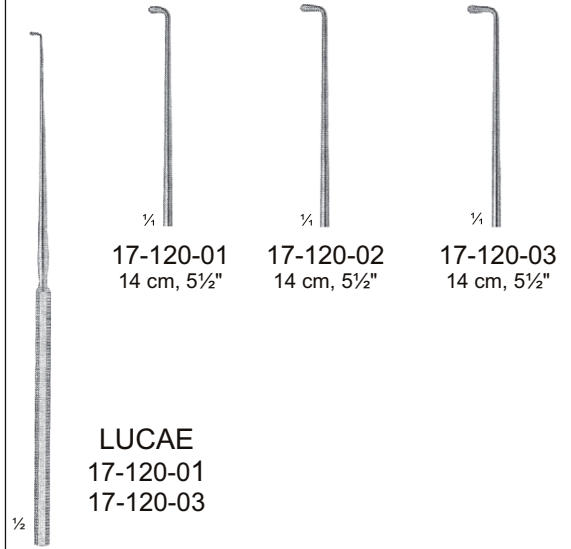

#### LUCAE

17-120-01  
 17-120-03

**Ear hooklets**  
 Ohrhäkchen  
 Ganchitos auriculares  
 Crochets auriculaires  
 Crochet auricolare

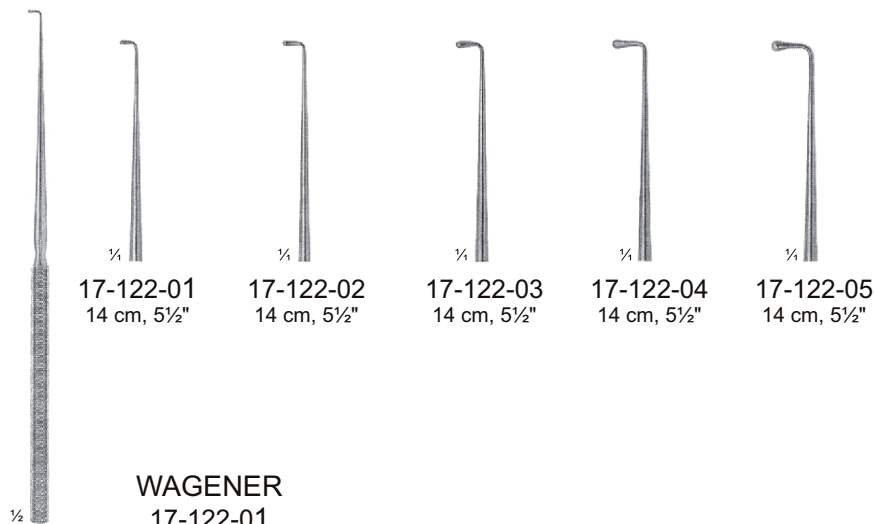

17-122-01	17-122-02	17-122-03	17-122-04	17-122-05
14 cm, 5½"	14 cm, 5½"	14 cm, 5½"	14 cm, 5½"	14 cm, 5½"

#### WAGENER

17-122-01  
 17-122-05

**Ear hooklets**  
 Ohrhäkchen  
 Ganchitos auriculares  
 Crochets auriculaires  
 Crochet auricolare



17-126-01	17-126-02	17-126-03
13 cm, 5"	14 cm, 5½"	14,5 cm, 5¾"

#### GRAEFE

17-126-01  
 17-126-03

**Strabismus hooks**  
 Schielhaken  
 Ganchos para estrabismo  
 Crochets à strabisme  
 Crochet per strabismo



**Wound and Nerve Hooks**

Wund- und Hauthäkchen (Nervhäkchen)  
 Ganchos y ganchitos para nervios  
 Ecarteurs très fins et crochets à nerfs  
 Divaricatori finin (Uncini per nervi)

017



 <p>17-130-14 14,5 cm, 5 3/4"</p> <p>17-130-20 20 cm, 8"</p> <p><b>CRILE</b> 17-130-14 17-130-20</p>	 <p>17-132-20 20 cm, 8"</p> <p>17-133-20 20 cm, 8"</p> <p><b>Blunt</b> Stumpf Romo Mousse Smusso</p> <p><b>Sharp</b> Spitz Agudo Pointu Acuto</p> <p><b>CUSHING</b> 17-132-20 17-133-20</p>	 <p>17-136-01 19 cm, 7 1/2"</p> <p>17-136-02 19 cm, 7 1/2"</p> <p><b>CUSHING</b> 17-136-01 17-136-02</p>	 <p>17-138-01 28 cm, 11"</p> <p>17-138-02 28 cm, 11"</p> <p><b>ADSON</b> 17-138-01 17-138-02</p>
---	--	---	---

 <p>17-142-18 18,5 cm, 7"</p> <p><b>CRILE</b> 17-142-18</p>	 <p>17-143-17 17 cm, 6 3/4"</p> <p>17-144-17 17 cm, 6 3/4"</p> <p><b>CUSHING</b> 17-143-17 17-144-17</p>	 <p>17-147-02 16 cm, 6 1/2"</p> <p>17-147-02 16 cm, 6 1/2"</p> <p><b>CUSHING</b> 17-147-01 17-147-02</p>	<p><b>TITAN LIGHT</b></p> <p>17-148-01 16 cm, 6 1/2"</p> <p>17-148-02 16 cm, 6 1/2"</p> <p>17-148-03 16 cm, 6 1/2"</p> <p>17-150-01 16 cm, 6 1/2"</p> <p>17-150-02 16 cm, 6 1/2"</p> <p>17-150-03 16 cm, 6 1/2"</p> <p><b>CUSHING</b> 17-148-01 17-148-03</p> <p><b>CUSHING</b> 17-150-01 17-150-03</p> <p>Titan, Titane, Titanio</p>
--	---	---	--



### Wound and Nerve Hooks

Wund- und Hauthäkchen (Nervhäkchen)  
 Ganchos y ganchitos para nervios  
 Ecarteurs très fins et crochets à nerfs  
 Divaricatori finini (Uncini per nervi)

017

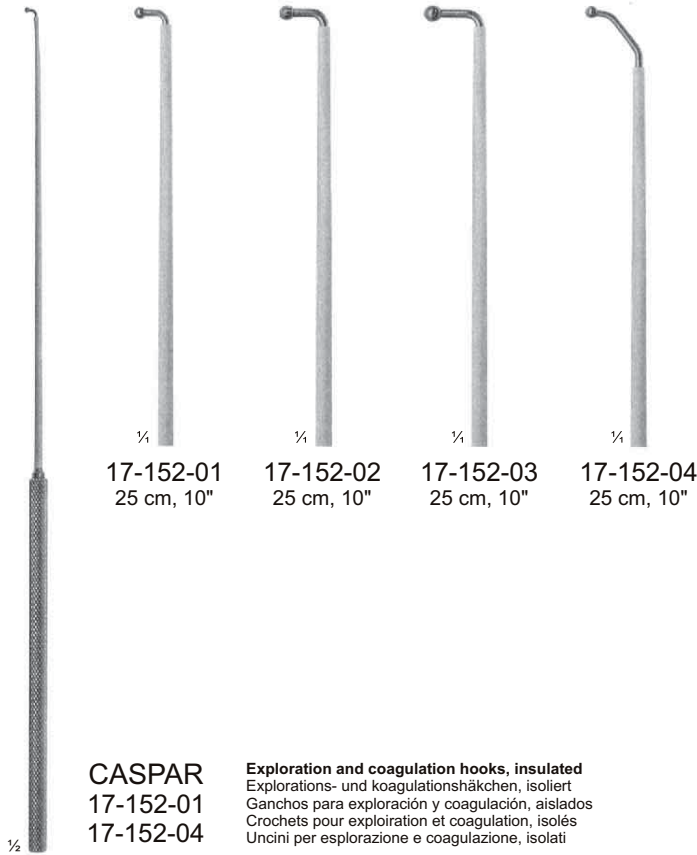

**CASPAR**  
 17-152-01  
 17-152-04

**Exploration and coagulation hooks, insulated**  
 Explorations- und koagulationshäkchen, isoliert  
 Ganchos para exploración y coagulación, aislados  
 Crochets pour exploration et coagulation, isolés  
 Uncini per esplorazione e coagulazione, isolati

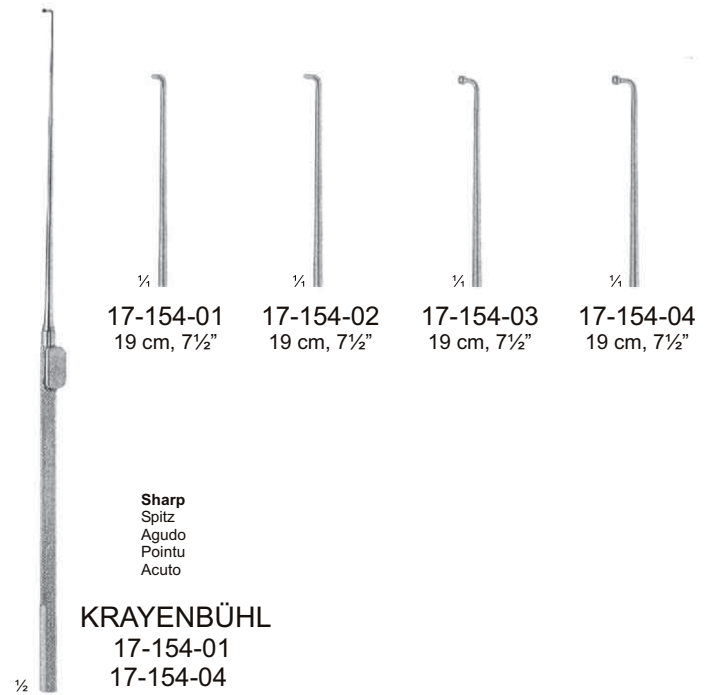

**KRAYENBÜHL**  
 17-154-01  
 17-154-04

**Sharp**  
 Spitz  
 Agudo  
 Pointu  
 Acuto

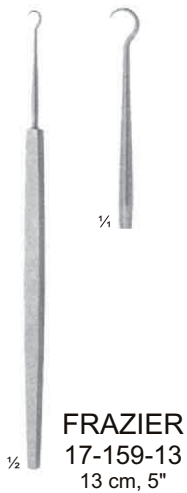

**FRAZIER**  
 17-159-13  
 13 cm, 5"

**Dura and skin retractor, sharp**  
 Dura- und Hauthäkchen, spitz  
 Gancho para piel y dura-madre, agudo  
 Crochet à peau et à dure-mère, pointu  
 Divaricatore per pelle e dura-madre, acuto



**GRAEFE**  
 17-165-01  
 17-165-02

**Skin retractors (Iris hooks)**  
 Hauthäkchen (Irishäkchen)  
 Ganchos para piel (gancho para iris)  
 Crochets à peau (Iris)  
 Divaricatori cutaneo (uncini per iride)



**KILNER**  
 17-167-13  
 13 cm, 5"

**Skin retractor, sharp**  
 Hauthäkchen, spitz  
 Gancho para piel, agudo  
 Crochet à peau, pointu  
 Divaricatore cutaneo, acuto



**KILNER**  
 17-173-15  
 15 cm, 6"

**Skin retractor, sharp**  
 Hauthäkchen, spitz  
 Gancho para piel, agudo  
 Crochet à peau, pointu  
 Divaricatore cutaneo, acuto

### Wound and Nerve Hooks

Wund- und Hauthäkchen (Nervhäkchen)  
 Ganchos y ganchitos para nervios  
 Ecarteurs très fins et crochets à nerfs  
 Divaricatori finini (Uncini per nervi)



**GILLIES**  
 17-177-18  
 18 cm, 7"

**Skin retractor, sharp**  
 Hauthäkchen, spitz  
 Gancho para piel, agudo  
 Crochet à peau, pointu  
 Divaricatore cutaneo, acuto



**GILLIES(CONVERSE)**  
 17-181-18  
 17-183-18  
 18 cm, 7"

**Dura and skin retractors, sharp**  
 Dura- und hauthäkchen, spitz  
 Ganchos para piel, y dura-madre, agudo  
 Crochets à peau et à dure-mère, pointus  
 Divaricatori per pelle e dura-madre, acuto

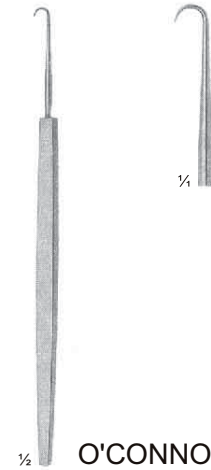

**O'CONNOR**  
 17-185-12  
 12,5 cm, 5"  
 17-185-16  
 16 cm, 6¼"

**Skin retractor (iris hook), sharp**  
 Hauthäkchen (irishäkchen), spitz  
 Gancho para piel (gancho para iris), agudo  
 Crochet à peau (iris), pointu  
 Uncino cutaneo (uncino per iride), acuto

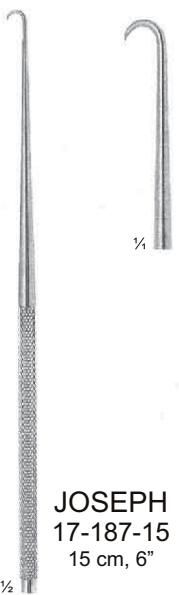

**JOSEPH**  
 17-187-15  
 15 cm, 6"

**Hook for plastic surgery, sharp**  
 Häkchen für plastische Chirurgie, spitz  
 Gancho para cirugía plástica, agudo  
 Crochet pour la chirurgie plastique, pointu  
 Uncino per chirurgia plastica, acuto

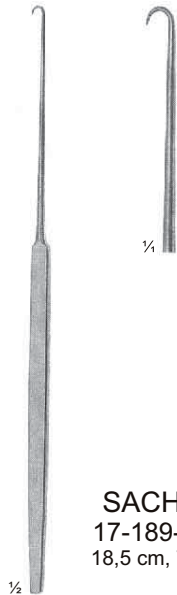

**SACHS**  
 17-189-18  
 18,5 cm, 7¼"

**Dura hook, sharp**  
 Durahäkchen, spitz  
 Gancho para dura-madre, agudo  
 Crochet pour la dure-mère, pointu  
 Uncino per dura-madre, acuto



**GRAHAM**  
 17-193-16  
 17-194-17

**Dura hook, blunt**  
 Durahäkchen, stumpf  
 Gancho para dura-madre, romo  
 Crochet pour la dure-mère, mousse  
 Uncino per dura-madre, smusso

### Wound and Nerve Hooks

Wund- und Hauthäkchen (Nervhäkchen)  
 Ganchos y ganchitos para nervios  
 Ecarteurs très fins et crochets à nerfs  
 Divaricatori finini (Uncini per nervi)

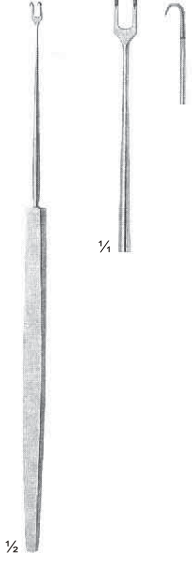

**FREER**  
 17-197-15  
 15 cm, 6"

**Sharp**  
 Spitz  
 Agudo  
 Pointu  
 Acuto

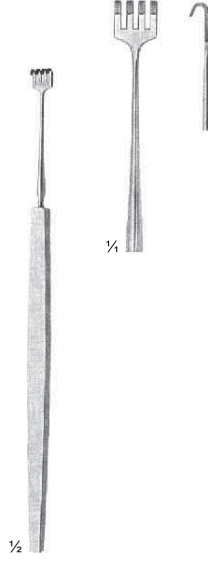

**KNAPP**  
 17-202-14  
 14 cm, 5½"

**Blunt**  
 Stumpf  
 Romo  
 Mousse  
 Smusso

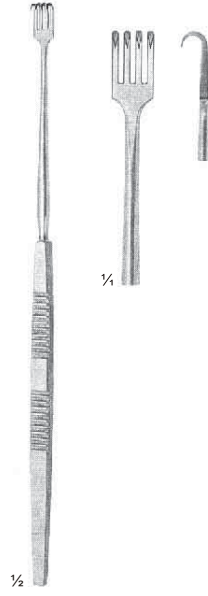

**KNAPP**  
 17-203-16  
 16 cm, 6¼"

**Sharp**  
 Spitz  
 Agudo  
 Pointu  
 Acuto

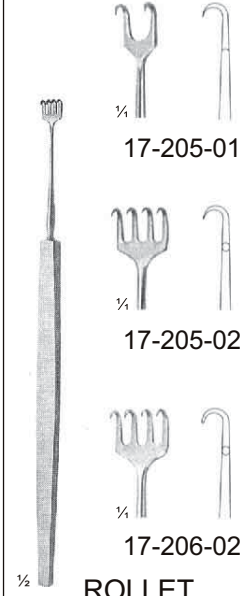

**ROLLET**  
 17-205-01  
 17-206-02  
 14 cm, 5½"

**Sharp**  
 Spitz  
 Agudo  
 Pointu  
 Acuto

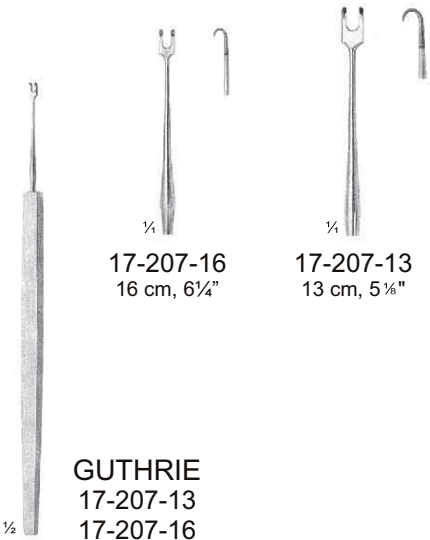

**GUTHRIE**  
 17-207-13  
 17-207-16

**Skin retractor (iris hook), sharp**  
 Hauthäkchen (Irishäkchen), spitz  
 Gancho para piel (gancho para iris), agudo  
 Crochet à plaies (Iris), pointu  
 Divaricatore cutaneo (uncino per iride), acuto

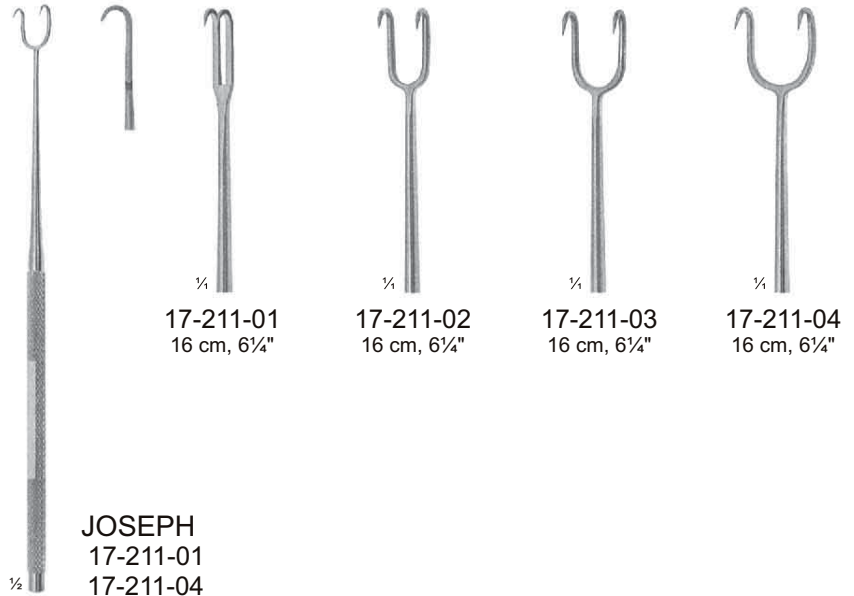

**JOSEPH**  
 17-211-01  
 17-211-04

**Hooks for plastic surgery, sharp**  
 Häkchen für plastische Chirurgie, spitz  
 Ganchos para cirugía plástica, agudos  
 Crochets pour la chirurgie plastique, pointu  
 Uncini per chirurgia plastica, acuti



17-213-01  
17-213-04

**Trachea retractors, sharp / flexible**  
 Trachealhäkchen, spitz / flexibel  
 Separadores para la tráquea, agudos / flexibles  
 Ecarteurs pour trachéotomie, pointu / flexible  
 Uncini tracheali, acuti / flessibili

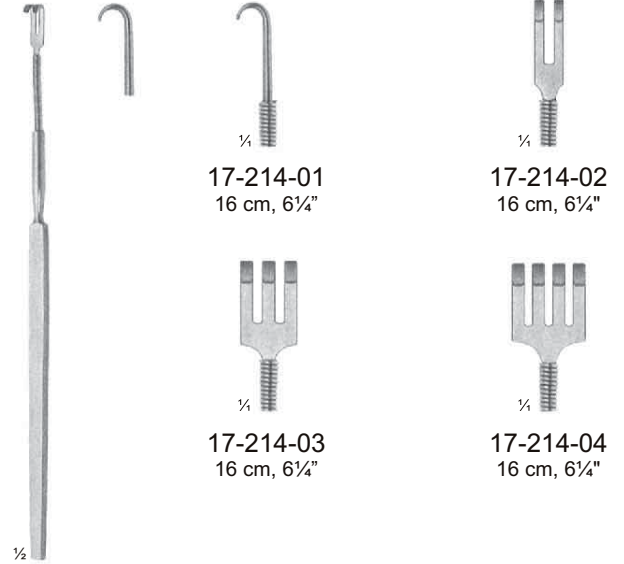

17-214-01  
17-214-04

**Trachea retractors, blunt / flexible**  
 Trachealhäkchen, stumpf / flexibel  
 Separadores para la tráquea, romos / flexibles  
 Ecarteurs pour trachéotomie, mousse / flexible  
 Uncini tracheali, smussi / flessibili

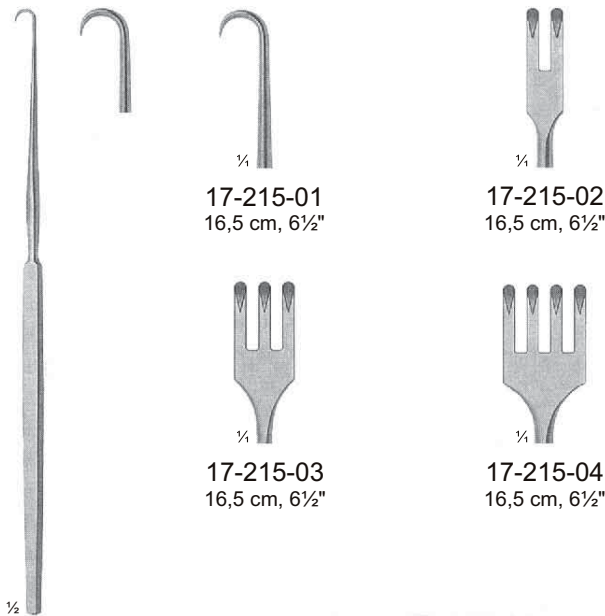

17-215-01  
17-215-04

**Trachea retractors, sharp**  
 Trachealhäkchen, spitz  
 Separadores para la tráquea, agudos  
 Ecarteurs pour trachéotomie, pointu  
 Uncini tracheali, acuti

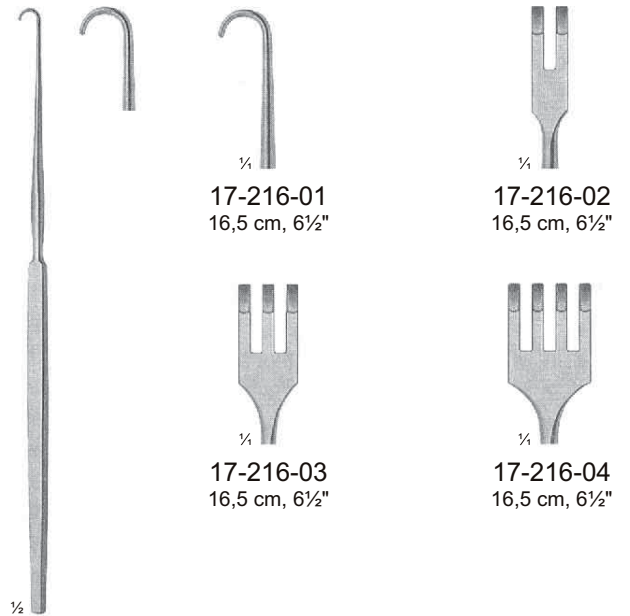

17-216-01  
17-216-04

**Trachea retractors, blunt**  
 Trachealhäkchen, stumpf  
 Separadores para la tráquea, romos  
 Ecarteurs pour trachéotomie, mousse  
 Uncini tracheali, smussi



17-221-01  
12 cm, 4<sup>3</sup>/<sub>4</sub>"

17-221-02  
12 cm, 4<sup>3</sup>/<sub>4</sub>"

**LAHEY**  
17-221-01  
17-221-02

Sharp  
Spitz  
Agudo  
Pointu  
Acuto

17-224-01  
17 cm, 6<sup>3</sup>/<sub>4</sub>"

17-226-01  
16 cm, 6<sup>1</sup>/<sub>4</sub>"

17-240-02  
17 cm, 6<sup>3</sup>/<sub>4</sub>"

**FOMON**  
17-224-01  
17-226-01  
17-240-02

Hook for posterior nares  
Choanenhaken  
Gancho para las coanas  
Crochet nasal  
Uncino per narici posteriori

17-231-01  
16 cm, 6<sup>1</sup>/<sub>4</sub>"

17-231-02  
16 cm, 6<sup>1</sup>/<sub>4</sub>"

**CUSHING**  
17-231-01  
17-231-02

Sharp  
Spitz  
Agudo  
Pointu  
Acuto

17-235-22  
22 cm, 8<sup>3</sup>/<sub>4</sub>"

17-237-01  
22 cm, 8<sup>3</sup>/<sub>4</sub>"

17-237-02  
22 cm, 8<sup>3</sup>/<sub>4</sub>"

**SIMON**  
17-235-22  
22 cm, 8<sup>3</sup>/<sub>4</sub>"

**EMMET**  
17-237-01  
17-237-02

Fistula hook  
Fistelhaken  
Gancho para fistulas  
Crochet pour fistules  
Uncino per fistole





17-250-01  
 17-250-01  
 17-250-01  
 4,5 x 9 mm

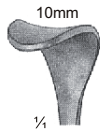

17-250-02  
 17-250-02  
 17-250-02  
 9 x 10 mm

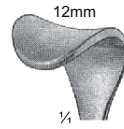

17-250-03  
 17-250-03  
 17-250-03  
 9 x 12 mm

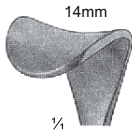

17-250-04  
 17-250-04  
 17-250-04  
 11 x 14 mm

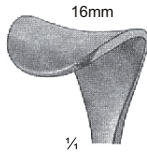

17-250-05  
 17-250-05  
 17-250-05  
 12 x 16 mm

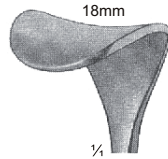

17-250-06  
 17-250-06  
 17-250-06  
 13 x 18 mm

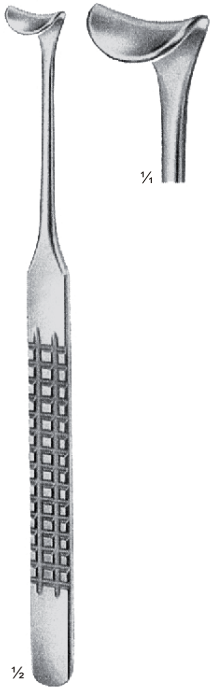

17-250-01  
 16 cm, 6¼"  
 17-250-06  
 16 cm, 6¼"



**DESMARRES**  
 17-254-01  
 17-254-06  
 13 cm, 5"



**CUSHING**  
 17-256-01  
 17-256-06  
 20 cm, 8"  
**Vein retractors**  
 Venenhaken  
 Separadores para venas  
 Ecarteurs à veines  
 Divaricatori per vene



**CUSHING**  
 17-258-01  
 17-258-06  
 24 cm, 9½"  
**Vein retractors**  
 Venenhaken  
 Separadores para venas  
 Ecarteurs à veines  
 Divaricatori per vene

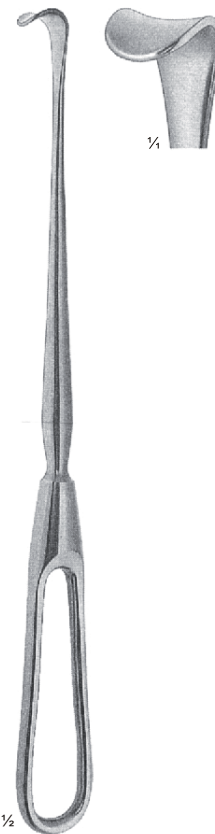

**CUSHING**  
 17-264-23  
 23 cm, 9"

**Vein retractor**  
 Venenhaken  
 Separador para venas  
 Ecartur a veines  
 Divaricatore per vene



**CUSHING**  
 17-266-20  
 20 cm, 8"

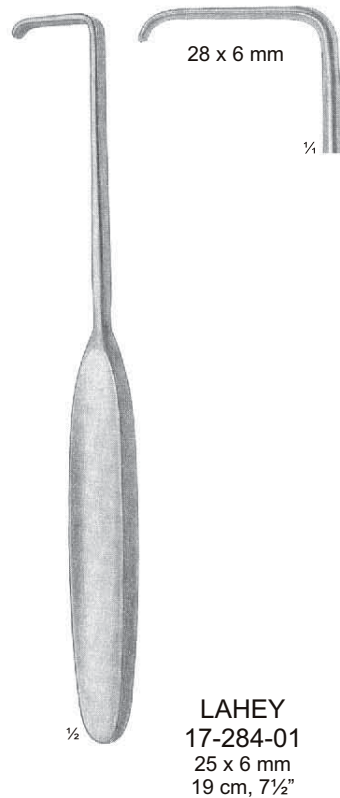
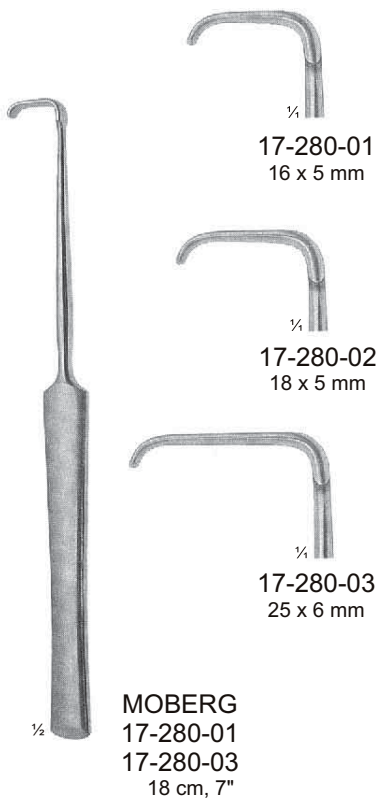
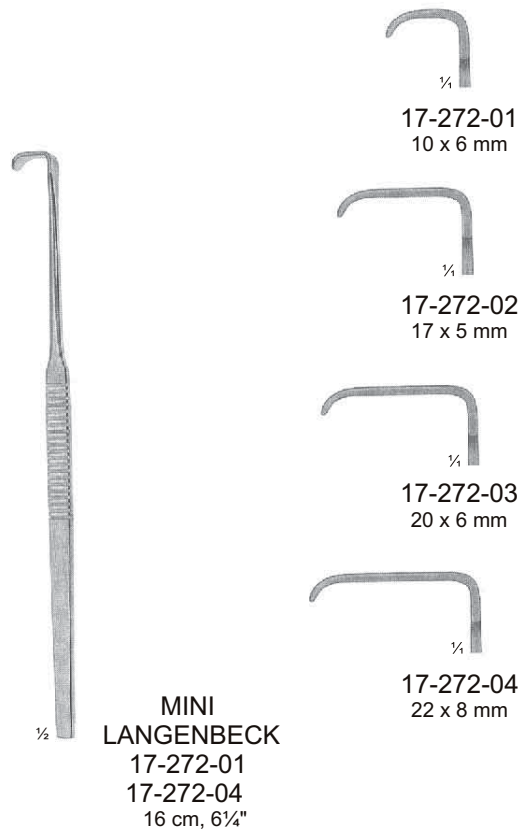

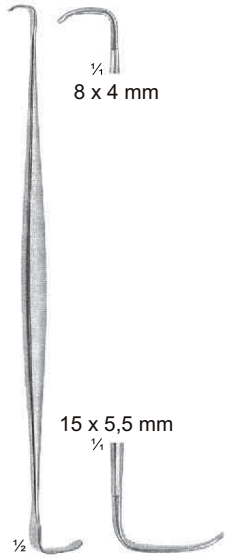

**RAGNELL-DAVIS**  
 17-292-14  
 14 cm, 5½"

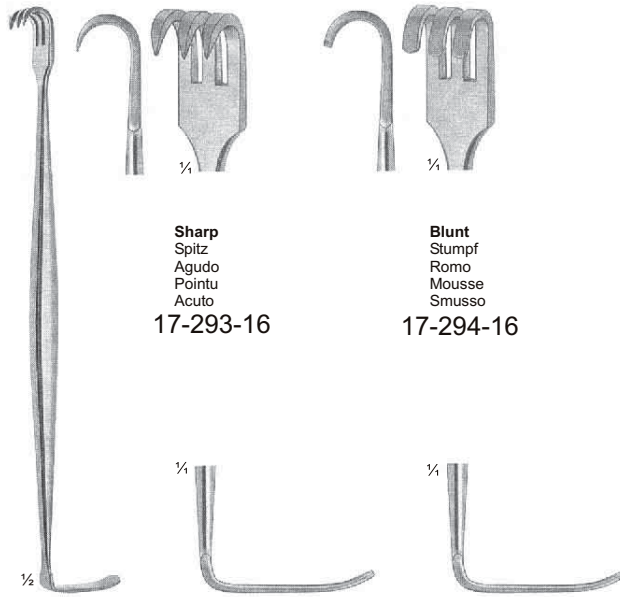

**Sharp**  
 Spitz  
 Agudo  
 Pointu  
 Acuto  
 17-293-16

**Blunt**  
 Stumpf  
 Romo  
 Mousse  
 Smusso  
 17-294-16

**SENN-MILLER**  
 17-293-16  
 17-294-16  
 16 cm, 6¼"



**CRILE**  
 17-296-11  
 11 cm, 4¼"



**LUER**  
 17-298-11  
 11 cm, 4½"

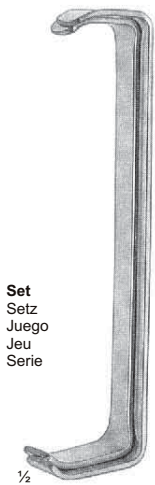

Set  
 Setz  
 Juego  
 Jeu  
 Serie

**FARABEUF**  
 17-300-12  
 12 cm, 4¾"



Set  
 Setz  
 Juego  
 Jeu  
 Serie

**FARABEUF**  
 17-302-15  
 15 cm, 5"



Set  
 Setz  
 Juego  
 Jeu  
 Serie

**PARKER**  
 17-308-14  
 14 cm, 5¼"



Set  
 Setz  
 Juego  
 Jeu  
 Serie

**PARKER**  
 17-310-18  
 18 cm, 7"

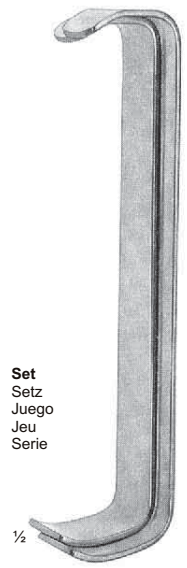

Set  
 Setz  
 Juego  
 Jeu  
 Serie

**COLLIN**  
 17-314-17  
 17 cm, 6½"



**STERNBERG**  
 17-320-01 12 cm, 4¾"  
 17-320-02 14 cm, 5½"  
 17-320-03 16 cm, 6¼"

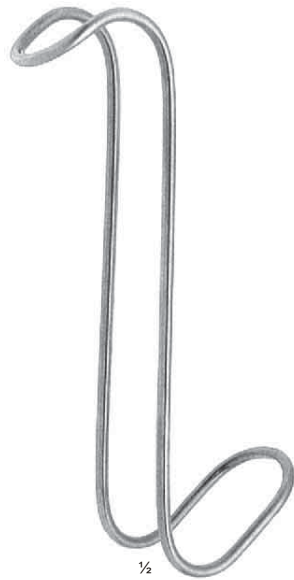

**COLLIN-HARTMANN**  
 17-322-14 14 cm, 5½"  
 17-322-16 16 cm, 6¼"



**BABY-ROUX**  
 17-326-13 13 cm, 5¼"

Set, fig 1-3  
 Setz Fig 1-3  
 Juego fig 1-3  
 Jeu fig 1-3  
 Serie fig 1-3

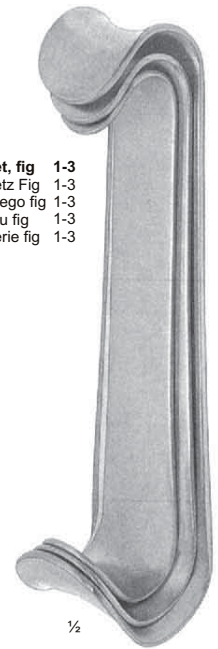

**ROUX**  
 17-328-17 17 cm, 6¾"  
 17-328-01 15 cm, 6"  
 17-328-02 16 cm, 6¼"  
 17-328-03 17 cm, 6¾"



**GOELET**  
 17-336-19 19 cm, 7½"

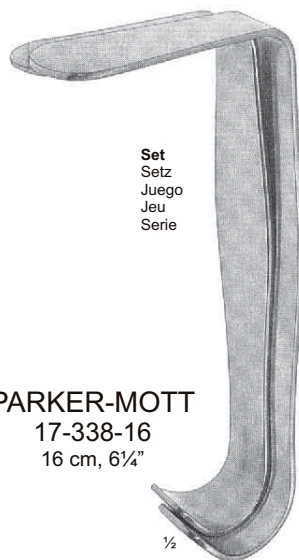

**PARKER-MOTT**  
 17-338-16 16 cm, 6¼"

Set  
 Setz  
 Juego  
 Jeu  
 Serie



**PARKER-LANGENBECK  
 (US-ARMY)**  
 17-340-21 21 cm, 8¼"

25X15mm  
 21X15mm

Set  
 Setz  
 Juego  
 Jeu  
 Serie

40X15mm  
 44X15mm



**MATHIEU**  
 17-342-20 20,5 cm, 8"

Set  
 Setz  
 Juego  
 Jeu  
 Serie

40X26mm  
 45X26mm



**VOLKMANN**  
17-345-01  
17-346-04  
11,5 cm, 4½"



¼  
17-345-01



¼  
17-345-02



¼  
17-345-03

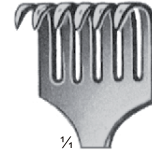

¼  
17-345-04

**Sharp**  
Scharf  
Agudo  
Pointu  
Acuto



¼  
17-346-01



¼  
17-346-02



¼  
17-346-03

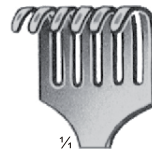

¼  
17-346-04

**Blunt**  
Stumpf  
Romo  
Mousse  
Smusso



¼  
**VOLKMANN**  
17-347-01  
17-348-02  
22 cm, 8¾"



¼  
17-347-01  
17-349-01

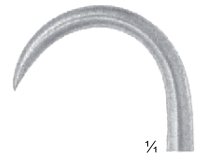

¼  
17-347-02  
17-349-02

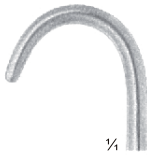

¼  
17-348-01  
17-350-01

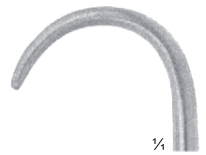

¼  
17-348-02  
17-350-02

**Sharp**  
Scharf  
Agudo  
Pointu  
Acuto

**Blunt**  
Stumpf  
Romo  
Mousse  
Smusso



¼  
**VOLKMANN**  
17-349-01  
17-350-02  
22 cm, 8¾"



¼  
**KOCHER**  
17-351-01  
17-352-02  
21,5 cm, 8½"



¼  
17-351-01  
21,5 cm, 8½"



¼  
17-351-02  
21,5 cm, 8½"

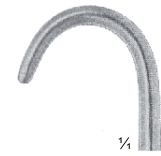

¼  
17-352-02  
21,5 cm, 8½"

**Sharp**  
Scharf  
Agudo  
Pointu  
Acuto

**Sharp**  
Scharf  
Agudo  
Pointu  
Acuto

**Blunt**  
Stumpf  
Romo  
Mousse  
Smusso



17-353-01  
17-363-01



17-354-01  
17-364-01



17-356-01  
17-366-01



17-353-02  
17-363-02



17-354-02  
17-364-02



17-356-02  
17-366-02



17-353-03  
17-363-03



17-354-03  
17-364-03



17-356-03  
17-366-03



17-353-04  
17-363-04



17-354-04  
17-364-04



17-356-04  
17-366-04



17-353-05  
17-363-05



17-354-05  
17-364-05



17-356-05  
17-366-05



17-353-06  
17-363-06



17-354-06  
17-364-06

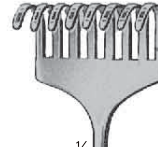

17-356-06  
17-366-06

**Sharp**  
Scharf  
Agudo  
Pointu  
Acuto

**Semi blunt**  
Stumpf  
Romo  
Mousse  
Smusso

**Blunt**  
Stumpf  
Romo  
Mousse  
Smusso



1/2  
**KOCHER**  
17-353-01  
17-355-06  
22cm, 8 3/4"



1/2  
**MARTIN**  
17-363-01  
17-365-06  
22cm, 8 3/4"



**Retractors**  
Wundhaken  
Separadores  
Ecarteurs  
Divaricatori



017

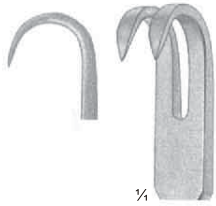

¼  
17-357-01  
17-367-01  
10 x 8 mm

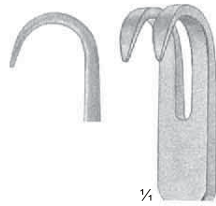

¼  
17-359-01  
17-369-01  
10 x 8 mm

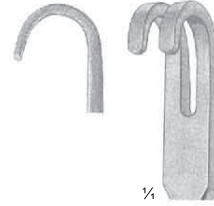

¼  
17-360-01  
17-370-01  
10 x 8 mm



¼  
17-357-02  
17-367-02  
10 x 13 mm



¼  
17-359-02  
17-369-02  
10 x 13 mm



¼  
17-360-02  
17-370-02  
10 x 13 mm



¼  
17-357-03  
17-367-03  
10 x 18 mm



¼  
17-359-03  
17-369-03  
10 x 18 mm



¼  
17-360-03  
17-370-03  
10 x 18 mm

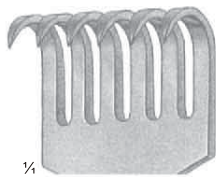

¼  
17-357-04  
17-367-04  
10 x 28 mm

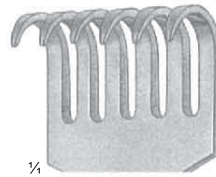

¼  
17-359-04  
17-369-04  
10 x 28 mm

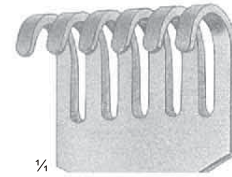

¼  
17-360-04  
17-370-04  
10 x 28 mm

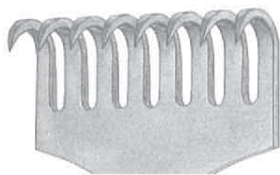

¼  
17-357-05  
17-367-05  
10 x 40 mm

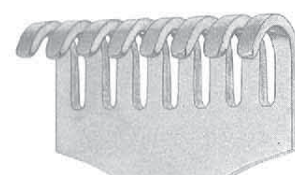

¼  
17-360-05  
17-370-05  
10 x 40 mm

**Semi Sharp**  
Scharf  
Agudo  
Pointu  
Acuto

**Sharp**  
Scharf  
Agudo  
Pointu  
Acuto

**Blunt**  
Stumpf  
Romo  
Mousse  
Smusso



½  
**VOLKMANN**  
17-357-01  
17-367-05  
22 cm, 8¾"



½  
**VOLKMANN**  
17-367-01  
17-370-05  
23 cm, 9"



**Sharp**  
Scharf  
Agudo  
Pointu  
Acuto



17-373-01  
15 x 9 mm



17-373-02  
15 x 13 mm



17-373-03  
15 x 18 mm

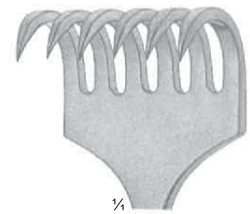

17-373-04  
15 x 30 mm



**Semi blunt**  
Stumpf  
Romo  
Mousse  
Smusso



17-375-01  
15 x 9 mm



17-375-02  
15 x 13 mm



17-375-03  
15 x 18 mm

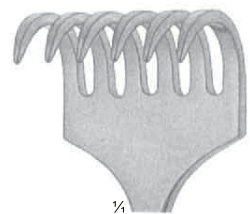

17-375-04  
15 x 30 mm



**Blunt**  
Stumpf  
Romo  
Mousse  
Smusso



17-376-01  
15 x 9 mm



17-376-02  
15 x 13 mm



17-376-03  
15 x 18 mm

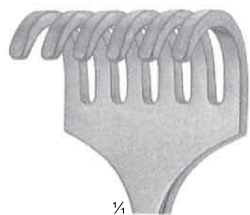

17-376-04  
15 x 30 mm



1/2  
**KOCHER**  
17-373-01  
17-376-04  
22 cm, 8 3/4"





**Blunt**  
Stumpf  
Romo  
Mousse  
Smusso

$\frac{1}{2}$   
**OLLIER**  
17-380-03  
22,5 cm, 9"  
17-380-04  
22,5 cm, 9"



**Sharp**  
Scharf  
Agudo  
Pointu  
Acuto

$\frac{1}{2}$   
**KOERTE-WAGNER**  
17-383-28  
28 cm, 11"

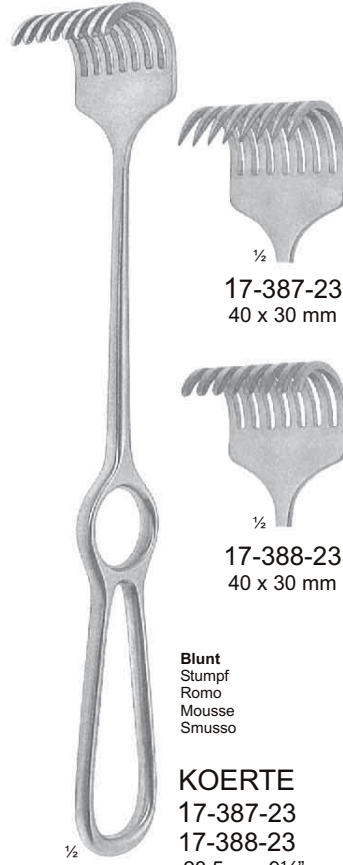

**Blunt**  
Stumpf  
Romo  
Mousse  
Smusso

$\frac{1}{2}$   
**KOERTE**  
17-387-23  
17-388-23  
40 x 30 mm  
23,5 cm, 9 $\frac{1}{4}$ "

**Handle vertical to the blade**  
Griff vertikal zum blatt  
Mango vertical a la hoja  
Manche vertical à la valve  
Impugnatura verticale a lama



**Blunt**  
Stumpf  
Romo  
Mousse  
Smusso

$\frac{1}{2}$   
**KOERTE**  
17-390-23  
23,5 cm, 9 $\frac{1}{4}$ "

**Handle vertical to the blade**  
Griff vertikal zum blatt  
Mango vertical a la hoja  
Manche vertical à la valve  
Impugnatura verticale a lama



$\frac{1}{3}$   
**ISRAEL**  
17-396-01  
17-396-04  
25 cm, 10"

**Blunt**  
Stumpf  
Romo  
Mousse  
Smusso



$\frac{1}{2}$   
17-396-01  
40 x 40 mm



$\frac{1}{2}$   
17-396-02  
45 x 50 mm

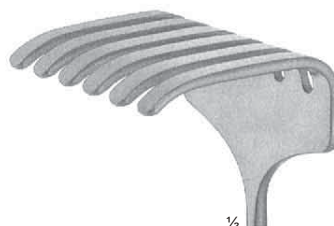

$\frac{1}{2}$   
17-396-03  
50 x 60 mm

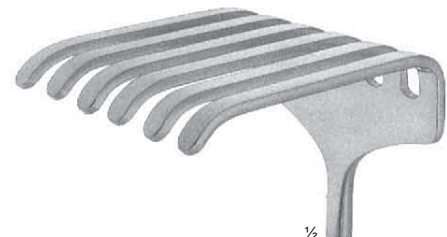

$\frac{1}{2}$   
17-396-04  
70 x 70 mm



17-416-01 ¼  
17-418-01  
30 x 11 mm



17-416-02 ¼  
17-418-02  
30 x 14 mm

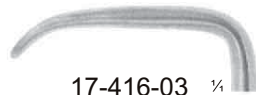

17-416-03 ¼  
17-418-03  
30 x 16 mm



17-416-04 ¼  
17-418-04  
40 x 10 mm



17-416-05 ¼  
17-418-05  
40 x 11 mm



17-416-06 ¼  
17-418-06  
40 x 15 mm

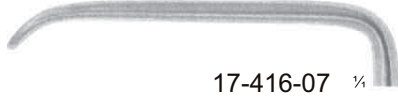

17-416-07 ¼  
17-418-07  
50 x 11 mm



½

**LANGENBECK**

17-416-01  
17-416-07  
21 cm, 8¼"



½

**LANGENBECK**

17-418-01  
17-418-07  
22 cm, 8½"



17-420-05  
75 x 40 mm ¼



17-420-04  
75 x 30 mm ¼

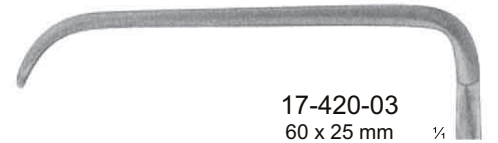

17-420-03  
60 x 25 mm ¼



17-420-02  
60 x 20 mm ¼



17-420-01  
40 x 18 mm ¼



½

**KOCHER**

17-420-01  
17-420-05  
23 cm, 9"



17-424-01  
 55 x 20 mm

¼



17-424-02  
 60 x 20 mm

¼



½

**LANGENBECK**  
 17-424-01 21,5 cm, 8½"  
 17-424-02 21,5 cm, 8½"



85 x 15 mm

¼



½

**LANGENBECK**  
 17-428-22  
 22,5 cm, 8¾"



1/2

**KOCHER  
LAGENBECK**  
17-434-01  
17-434-09  
22 cm, 8 1/2"

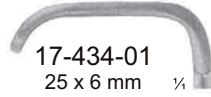

17-434-01  
25 x 6 mm 1/4

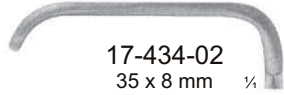

17-434-02  
35 x 8 mm 1/4

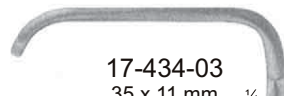

17-434-03  
35 x 11 mm 1/4

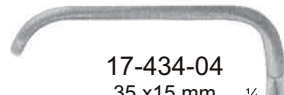

17-434-04  
35 x 15 mm 1/4



17-434-05  
40 x 11 mm 1/4



17-434-06  
55 x 11 mm 1/4



17-434-07  
70 x 14 mm 1/4



17-434-08  
80 x 12 mm 1/4



17-434-09  
80 x 16 mm 1/4



1/2

17-440-03 40 x 10 mm  
17-440-04 40 x 15 mm  
17-440-05 40 x 20 mm

**KOCHER**  
17-440-01  
17-440-05  
22 cm, 8 1/2"



17-440-01  
19 x 12 mm 1/4



17-440-02  
21 x 14 mm 1/4

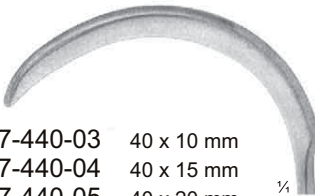

1/4

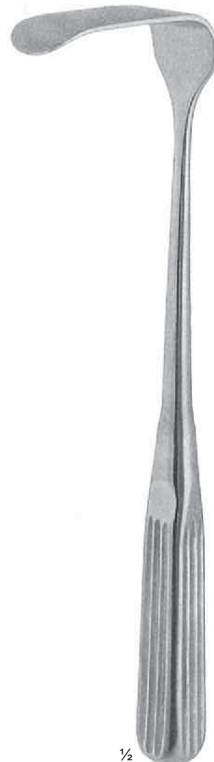

1/2

**SAUERBRUCH**  
17-444-01  
17-444-03  
25 cm, 10"



17-444-01  
45 x 15 mm 1/4

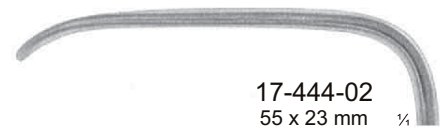

17-444-02  
55 x 23 mm 1/4



17-444-03  
72 x 20 mm 1/4

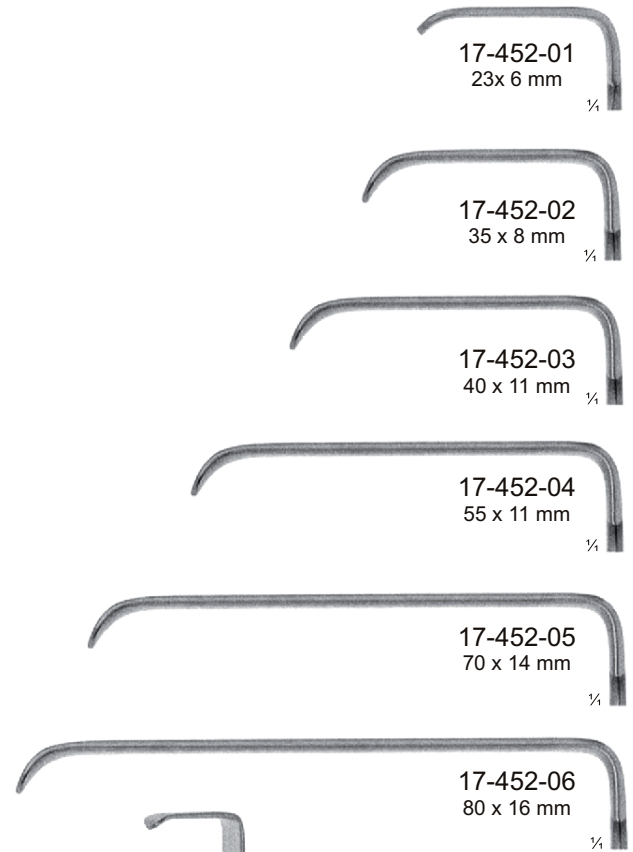
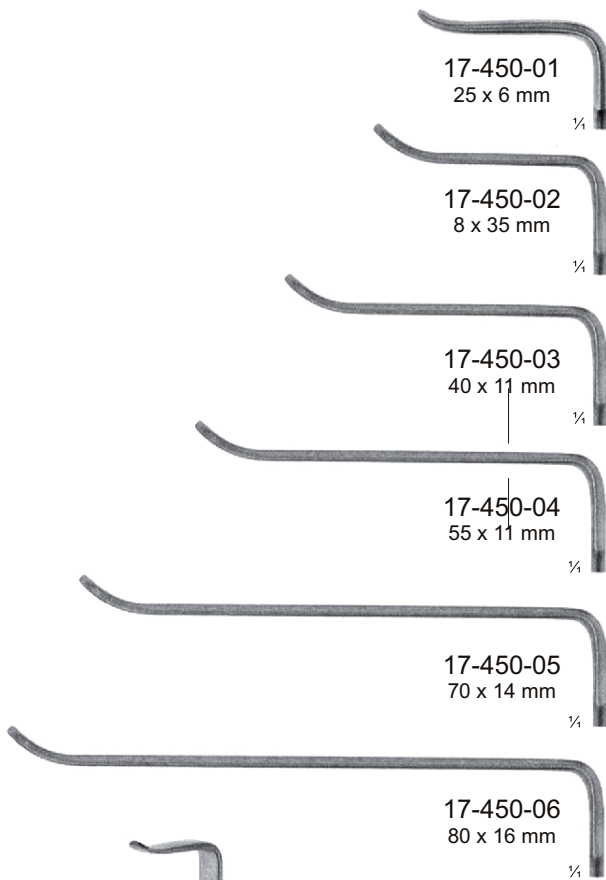

**OBWEGESER**  
17-450-01  
17-450-06  
22 cm, 8¾"

**Soft tissue retractors**  
Weichteilhaken  
Separadores para tejido blando  
Ecarteurs pour parties molles  
Divaricatori per tessuti molli



**OBWEGESER**  
17-452-01  
17-452-06  
21,5 cm, 8½"

**Soft tissue retractors**  
Weichteilhaken  
Separadores para tejido blando  
Ecarteurs pour parties molles  
Divaricatori per tessuti molli



17-458-01  
45 X 45 mm



17-458-02  
45 X 50 mm



17-458-03  
55 X 70 mm



**MIDDELDORPF**  
17-458-01  
17-458-03  
25,5 cm, 10"



17-460-01  
14 X 17 mm  
21,5 cm, 8½"



17-460-02  
20 X 22 mm  
22,5 cm, 8¾"



17-460-03  
26 X 30 mm  
23,5 cm, 9½"



**MIDDELDORPF**  
17-460-01  
17-460-03



17-466-22  
22 x 20 mm



**Thyroid gland retractor**  
Schilddrüsenhaken  
Separador para la glándula tiroidea  
Ecarteur pour la thyroïde  
Divaricatore per la tiroide

**GREEN**  
17-466-22  
22 cm, 8¾"

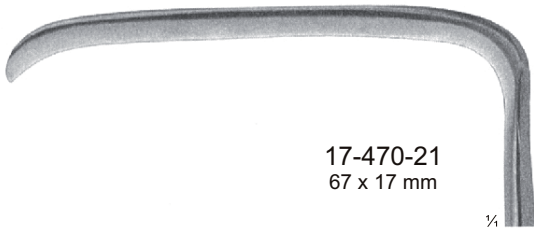

17-470-21  
 67 x 17 mm

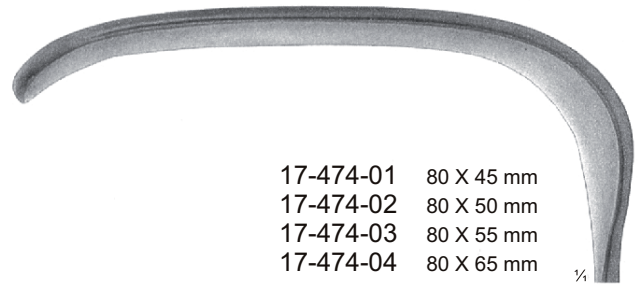

17-474-01 80 X 45 mm  
 17-474-02 80 X 50 mm  
 17-474-03 80 X 55 mm  
 17-474-04 80 X 65 mm



½

**CASPAR**  
 17-470-21  
 21,5 cm, 8½"



½

**KOCHER**  
 17-474-01  
 17-474-04  
 25 cm, 10"



**Retractors**  
Wundhaken  
Separadores  
Ecarteurs  
Divaricatori



017

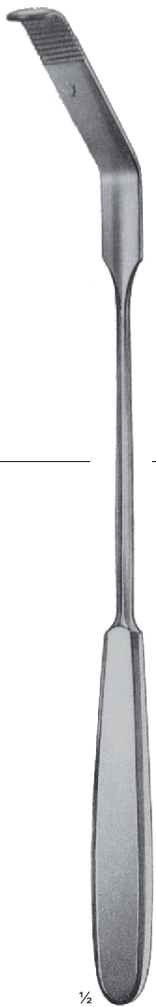

1/2

**ZENKER**  
17-480-01  
17-480-05



1/2

**KOCHER**  
17-478-01  
17-478-05  
23 cm, 9"



**17-478-01**  
40 x 18 mm

1/4

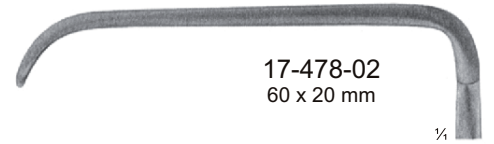

**17-478-02**  
60 x 20 mm

1/4



**17-478-03**  
60 x 25 mm

1/4



**17-478-04**  
75 x 30 mm

1/4

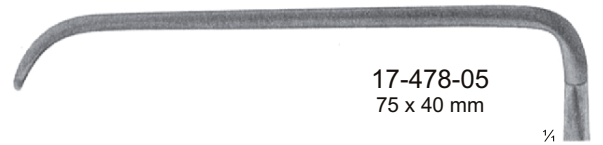

**17-478-05**  
75 x 40 mm

1/4

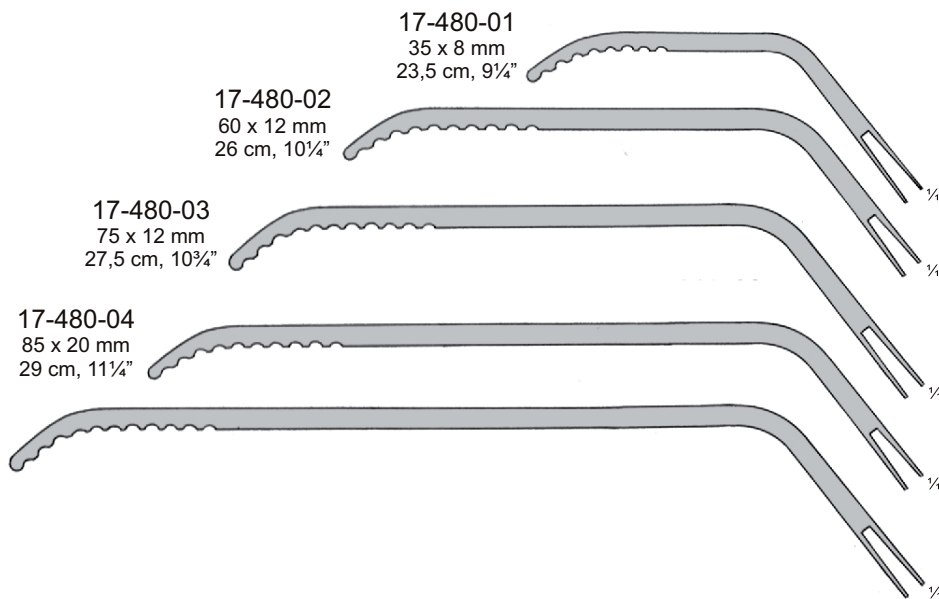

**17-480-01**  
35 x 8 mm  
23,5 cm, 9 1/4"

**17-480-02**  
60 x 12 mm  
26 cm, 10 1/4"

**17-480-03**  
75 x 12 mm  
27,5 cm, 10 3/4"

**17-480-04**  
85 x 20 mm  
29 cm, 11 1/4"

**17-480-05**  
100 x 25 mm  
30 cm, 12"

1/4

1/4

1/4

1/4

1/4





½

**DOYEN**  
17-488-01  
17-488-11  
23 cm, 9"

**Abdominal retractor**  
Bauchdeckenhaken  
Separadores abdominales  
Ecarteurs intra abdominaux  
Divaricatori addominale

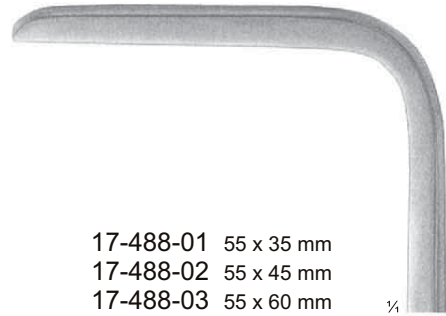

17-488-01 55 x 35 mm  
17-488-02 55 x 45 mm  
17-488-03 55 x 60 mm

¼

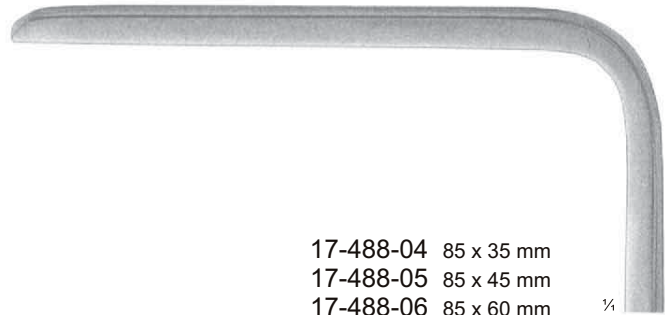

17-488-04 85 x 35 mm  
17-488-05 85 x 45 mm  
17-488-06 85 x 60 mm

¼

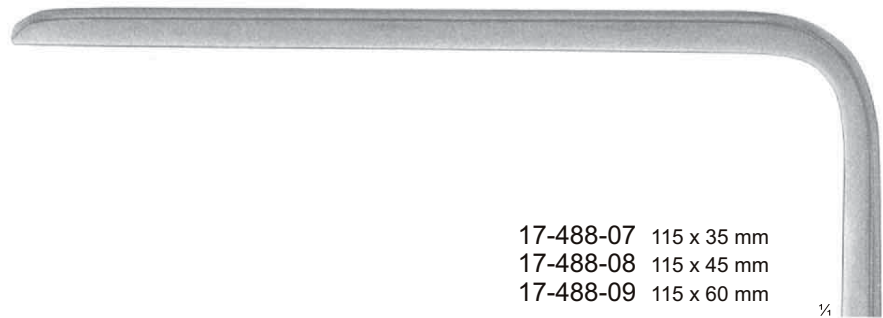

17-488-07 115 x 35 mm  
17-488-08 115 x 45 mm  
17-488-09 115 x 60 mm

¼



17-488-10 160 x 45 mm  
17-488-11 160 x 60 mm

¼



17-492-01 30 x 30 mm  
17-492-02 32 x 40 mm



¼

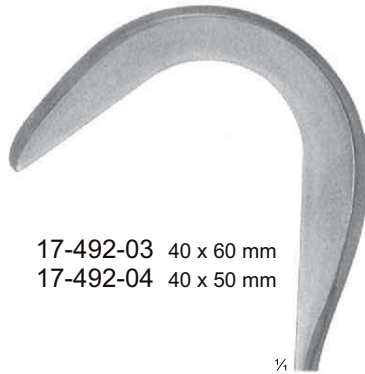

17-492-03 40 x 60 mm  
17-492-04 40 x 50 mm

¼



17-494-24  
50 x 85 mm

¼

**Handle vertical to the blade**  
Griff vertikal zum blatt  
Mango vertical a la hoja  
Manche vertical à la valve  
Impugnatura verticale a lama

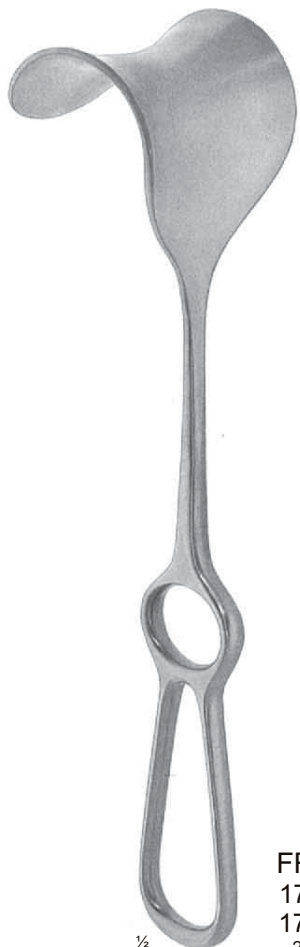

½



17-492-05  
45 x 75 mm

¼

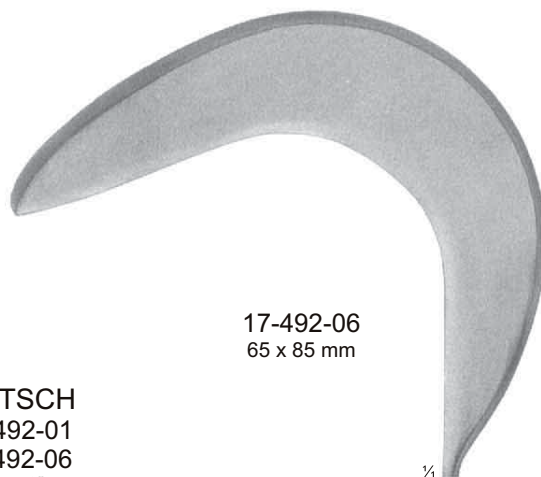

17-492-06  
65 x 85 mm

¼

**FRITSCH**  
17-492-01  
17-492-06  
23 cm, 9"



½

**Abdominal retractor**  
Bauchdeckenhaken  
Separador abdominal  
Ecarteur intra abdominaux  
Divaricatore addominale

**DOYEN**  
17-494-24  
25 cm, 10"



**RICHARDSON**  
17-496-01  
17-496-04  
24 cm, 9½"

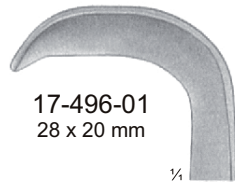

17-496-01  
28 x 20 mm



17-496-02  
36 x 28 mm



17-496-03  
44 x 38 mm

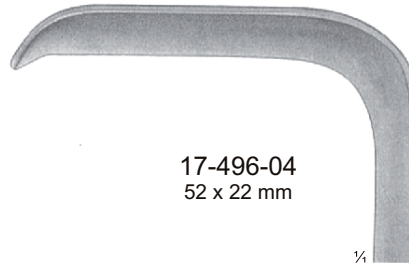

17-496-04  
52 x 22 mm

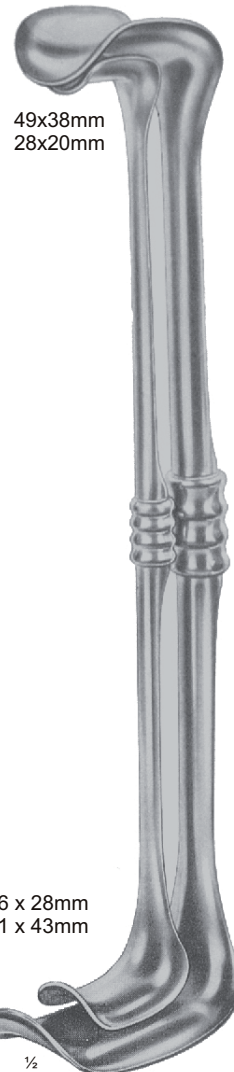

49x38mm  
28x20mm

36 x 28mm  
71 x 43mm

**RICHARDSON  
EASTMAN**  
17-502-01  
17-502-02  
26 cm, 10¼"

Set  
Satz  
Juego  
Jeu  
Serie



**KELLY**  
17-498-01  
17-498-03  
26 cm, 10¼"

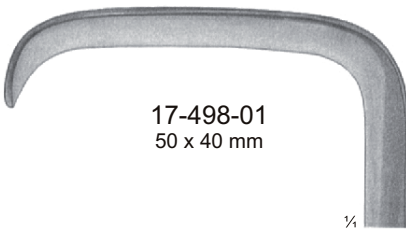

17-498-01  
50 x 40 mm

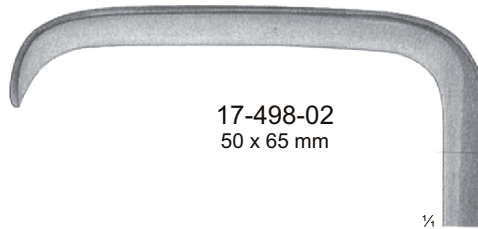

17-498-02  
50 x 65 mm

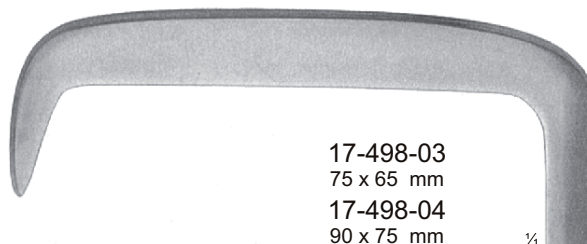

17-498-03  
75 x 65 mm  
17-498-04  
90 x 75 mm

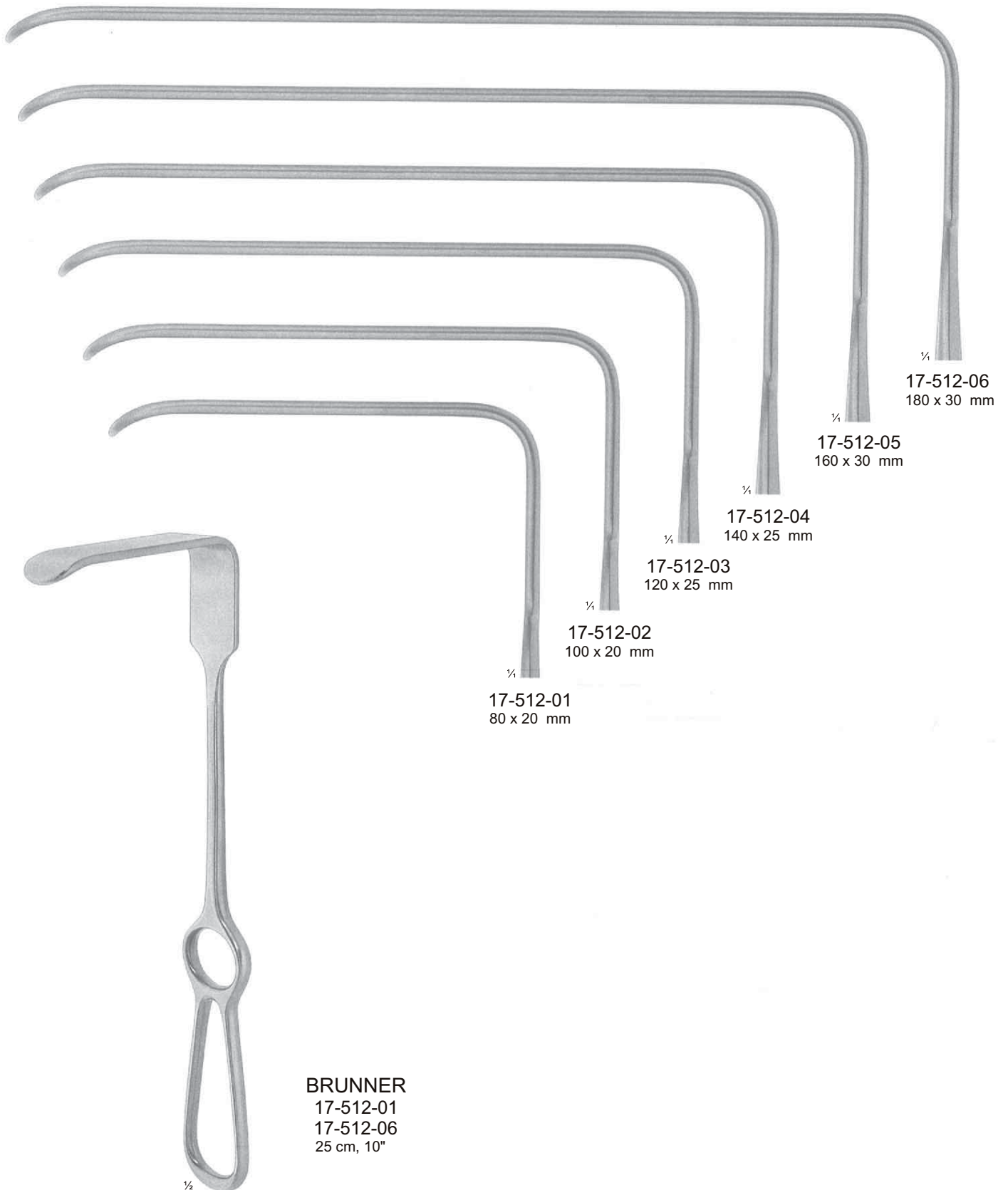



### Retractors for Deep Surgery

Wundhaken für Eingriffe in der tiefe  
Separadores para cirugía profunda  
Ecarteurs pour interventions en profondeur  
Divaricatori per interventi in profondità



017

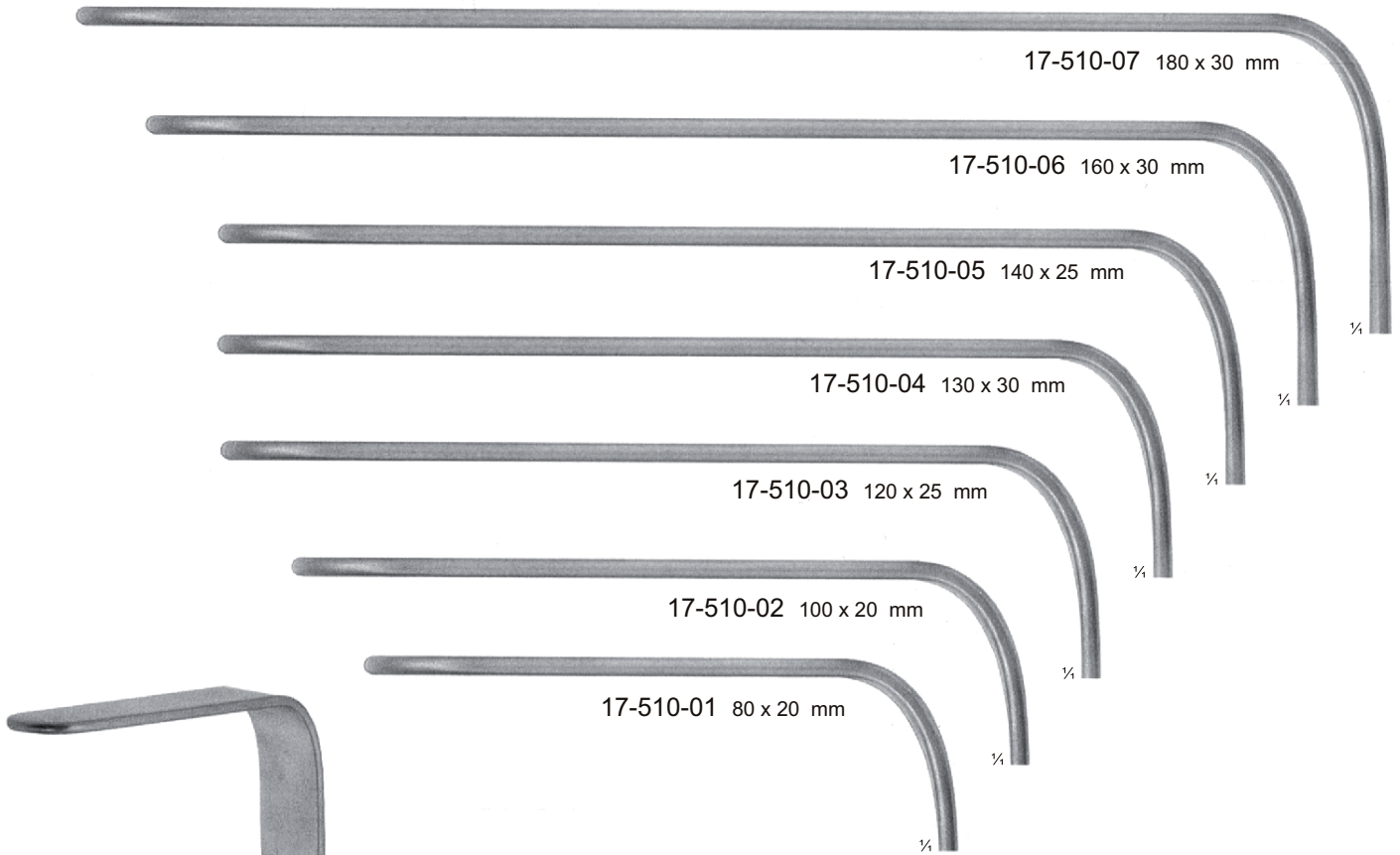

1/2

BRUNNER  
17-510-01  
17-510-07  
25 cm, 10"

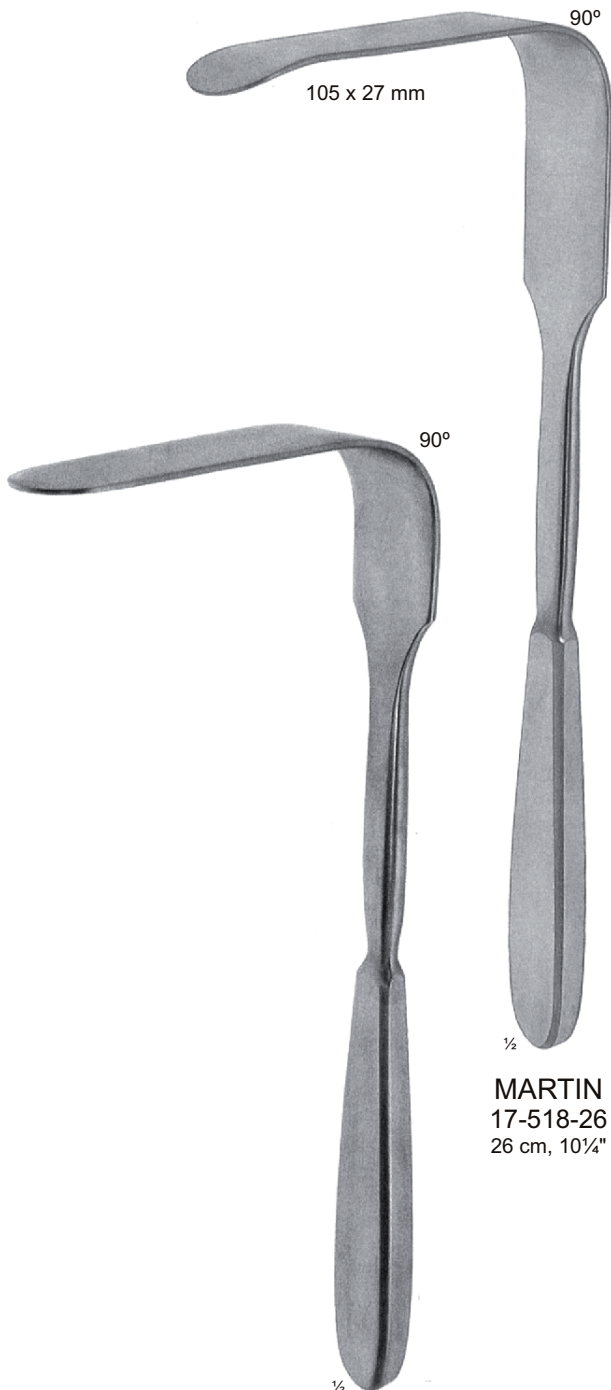

**SIMON**  
 17-516-01 115 x 22 mm  
 17-516-02 115 x 27 mm  
 28 cm, 11"

**MARTIN**  
 17-518-26  
 26 cm, 10¼"

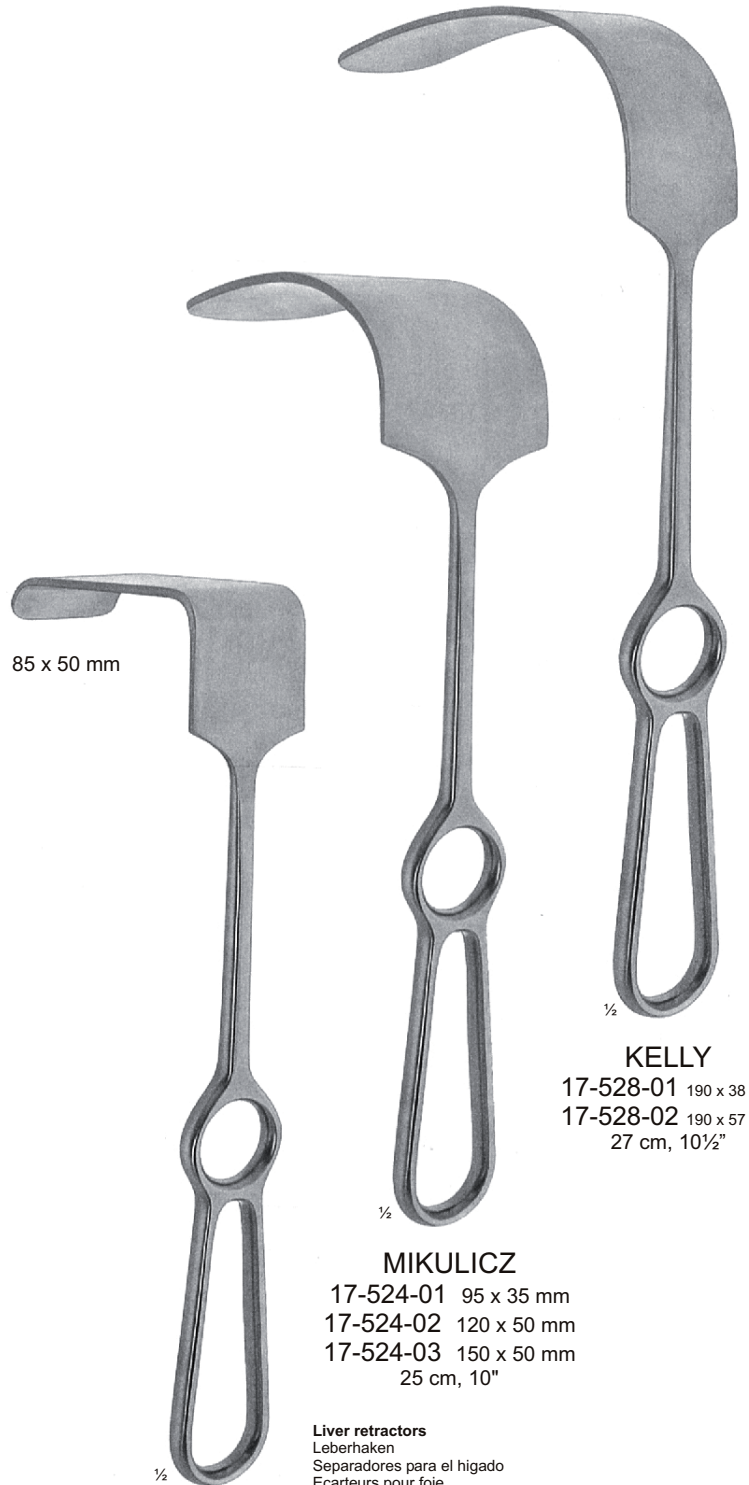

**MIKULICZ**  
 17-522-26  
 26 cm, 10¼"

**Liver retractors**  
 Leberhaken  
 Separadores para el hígado  
 Ecarteurs pour foie  
 Divaricatori per fegato

**MIKULICZ**  
 17-524-01 95 x 35 mm  
 17-524-02 120 x 50 mm  
 17-524-03 150 x 50 mm  
 25 cm, 10"

**KELLY**  
 17-528-01 190 x 38 mm  
 17-528-02 190 x 57 mm  
 27 cm, 10½"



**Retractors for Deep Surgery**  
Wundhaken für Eingriffe in der tiefe  
Separadores para cirugía profunda  
Ecarteurs pour interventions en profondeur  
Divaricatori per interventi in profondità



017

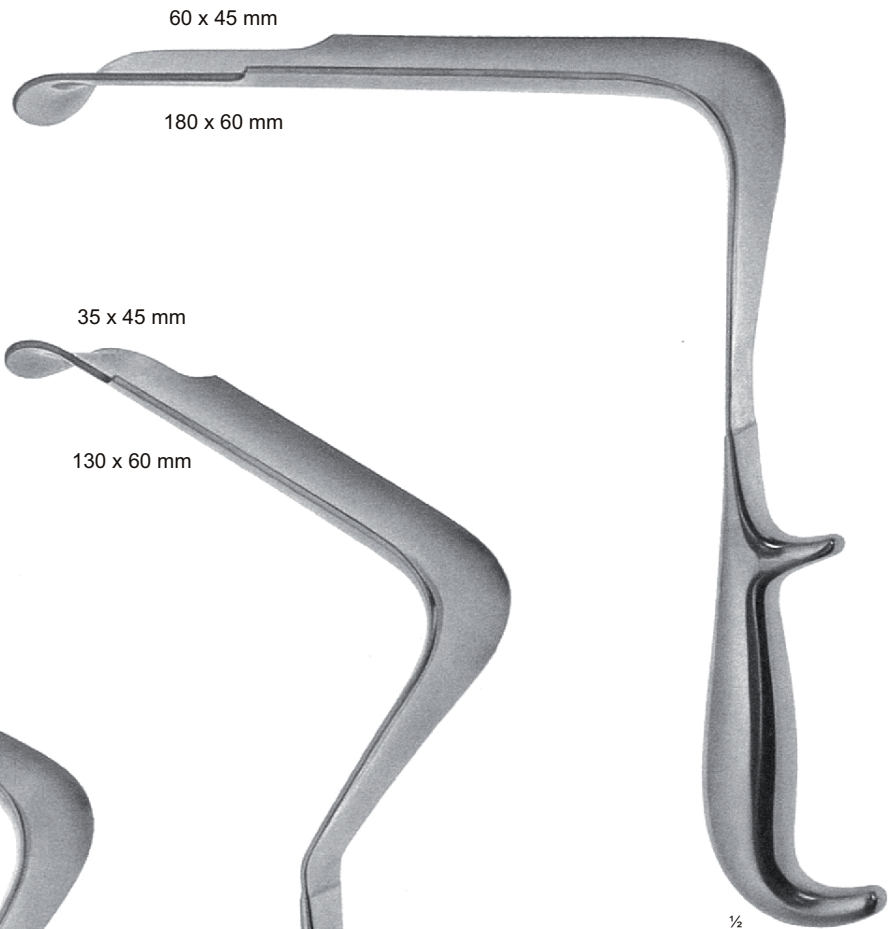

½  
**ST.MARKS**  
17-534-33  
33 cm, 13"  
**Pelvis retractor**  
Pelvishaken  
Separador para pelvis  
Ecarteur à pelvis  
Divaricatore per pelvis

½  
**ST.MARKS**  
17-532-29  
29 cm, 11½"  
**Pelvis retractor**  
Pelvishaken  
Separador para pelvis  
Ecarteur à pelvis  
Divaricatore per pelvis

**ST.MARKS**  
17-530-33  
33 cm, 13"  
**Pelvis retractor**  
Pelvishaken  
Separador para pelvis  
Ecarteur à pelvis  
Divaricatore per pelvis



### Lung Retractors

Lungenhaken  
Separadores para el pulmón  
Ecarteur à poumons  
Divaricatori per polmone

### Scapula Retractors

Scapula-Haken  
Separadores para scápula  
Ecarteur à scapula  
Divaricatori per scapola



017

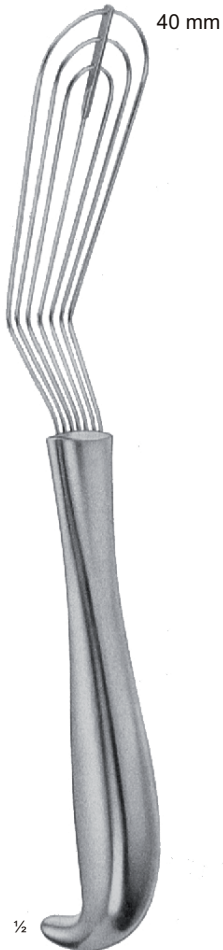

**ALLISON**  
17-540-25  
25 cm, 10"



**ALLISON**  
17-542-32  
32 cm, 12½"

**Lung spatula**  
Lungenspatel  
Espátula para el pulmón  
Spatule pulmonaire  
Spatole per polmone



**DAVIDSON**  
17-546-16  
16 cm, 6¼"

**Scapula retractor**  
Scapula-Haken  
Separador para Scápula  
Ecarteur à scapula  
Dicaricatore per scapola



**DAVIDSON**  
17-548-16  
16 cm, 6¼"

**Scapula retractor**  
Scapula-Haken  
Separador para Scápula  
Ecarteur à scapula  
Dicaricatore per scapola





**Retractors and Lung Spatulas**  
Wundhaken und Lungenspatel  
Separadores y espátulas para el pulmón  
Ecarteurs et spatules pulmonaires  
Divaricatori e spatole per polmone



017

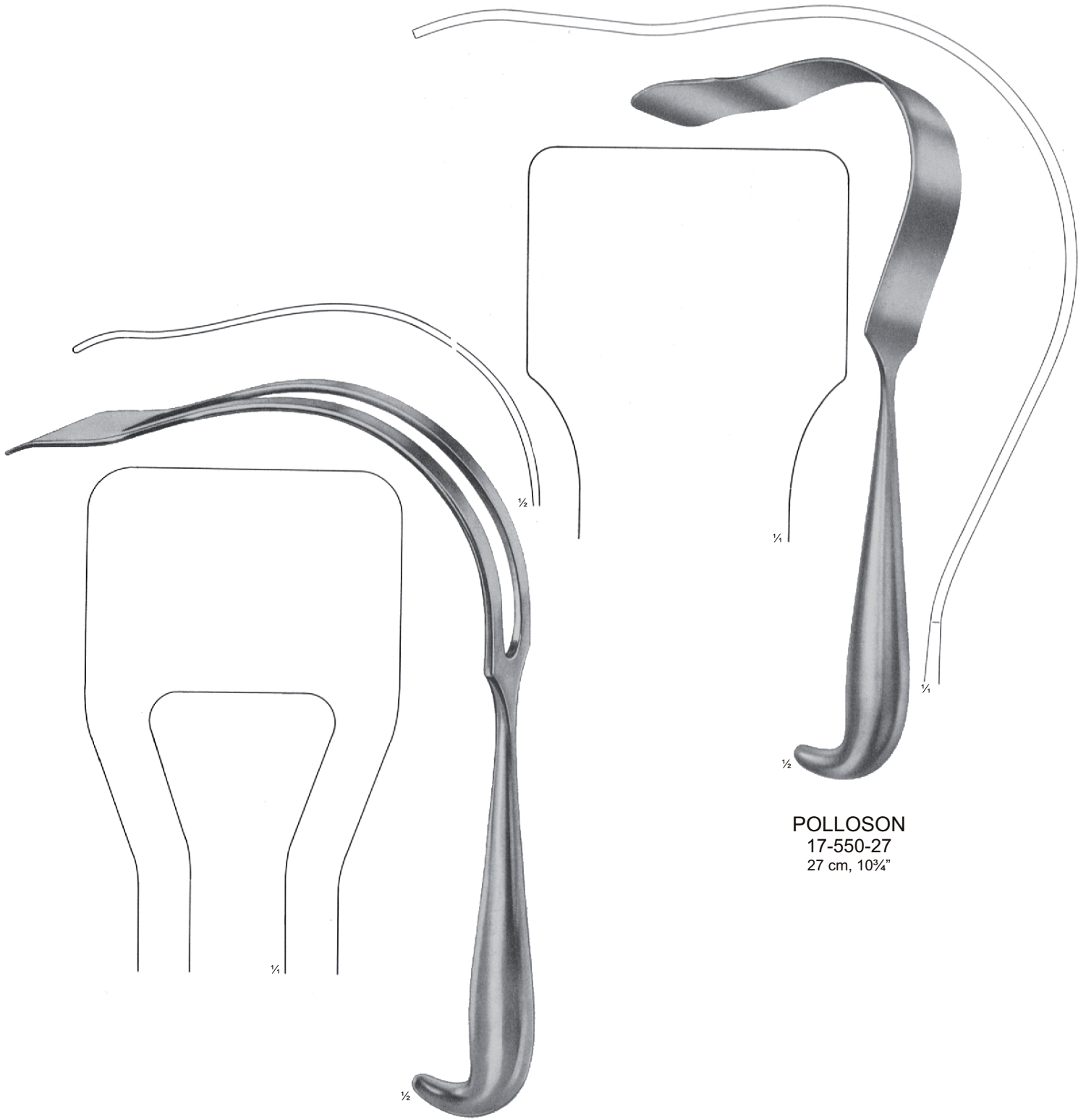

**POLLOSON**  
17-550-26  
26 cm, 10<sup>3</sup>/<sub>4</sub>"

**POLLOSON**  
17-550-27  
27 cm, 10<sup>3</sup>/<sub>4</sub>"

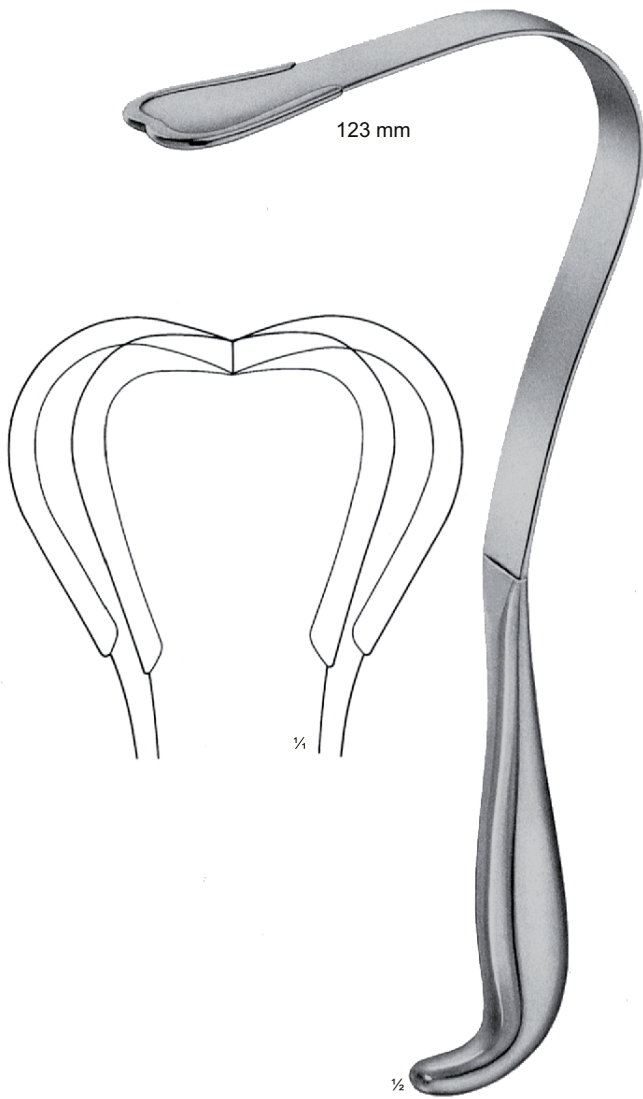

**HARRINGTON**  
 17-560-01 127 x 40 mm  
 17-562-02 127 x 62 mm  
 32 cm, 12½"

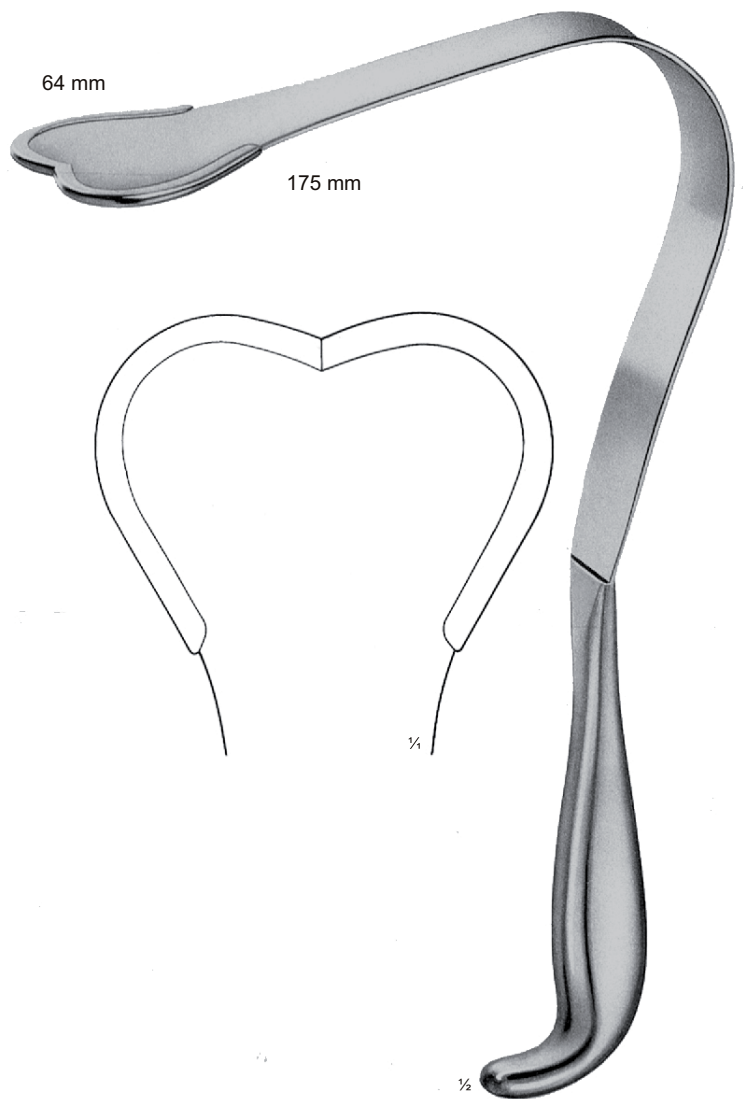

**HARRINGTON-PEMBERTON**  
 17-562-29  
 175 x 64 mm  
 29,5 cm, 11¾"



**Retractors and Lung Spatulas**  
Wundhaken und Lungenspatel  
Separadores y espátulas para el pulmón  
Ecarteurs et spatules pulmonaires  
Divaricatori e spatole per polmone



017

19 mm



¼

**DEAVER**  
17-570-01  
18 cm, 7"

22 mm



¼

**DEAVER**  
17-570-02  
21,5 cm, 8½"

25 mm



¼

**DEAVER**  
17-570-03  
23 cm, 9"

25 mm



¼

**DEAVER**  
17-570-04  
30 cm, 12"

25 mm



¼

**DEAVER**  
17-570-05  
30 cm, 12"

25 mm



¼

**DEAVER**  
17-570-06  
33 cm, 13"

25 mm



¼

**DEAVER**  
17-570-07  
36 cm, 14"

38 mm



¼

**DEAVER**  
17-570-08  
30 cm, 12"



50 mm

DEAVER  
 17-570-09  
 30 cm, 12"



25 mm

17-580-01  
 31 cm, 12¼"



38 mm

17-580-02  
 31 cm, 2¼"



75 mm

DEAVER  
 17-570-10  
 30 cm, 12"



DEAVER  
 17-580-01  
 17-580-04



50 mm

17-580-03  
 30,5 cm, 12"



75 mm

17-580-04 17-580-05  
 31 cm, 12¼" 31 cm, 12¼"



- ¼  
17-600-01  
20 mm
- 17-600-02  
30 mm
- 17-600-03  
40 mm



**KADER**  
 17-600-01  
 17-600-03  
 27,5 cm, 10¾"



- 17-610-06  
20cm x 6,5 mm
- 17-610-09  
20cm x 9,5 mm
- 17-610-13  
20cm x 13 mm
- 17-610-16  
20cm x 16 mm
- 17-610-19  
20cm x 19 mm
- 17-610-25  
20cm x 25 mm
- 17cm x 6¾"

17 x 25 mm



**TUFFIER**  
 17-614-01  
 20 cm, 8"



**HBERER**  
 17-618-01 17 x 25 mm  
 20 cm, 8"  
 17-618-02 25 x 30 mm  
 28 cm, 11"  
 17-618-03 37 x 45 mm  
 30 cm, 12"



- 17-622-01 330 x 20 mm
- 17-622-02 330 x 25 mm
- 17-622-03 330 x 30 mm
- 17-622-04 330 x 35 mm
- 17-622-05 330 x 40 mm
- 17-622-06 330 x 45 mm
- 17-622-07 330 x 50 mm

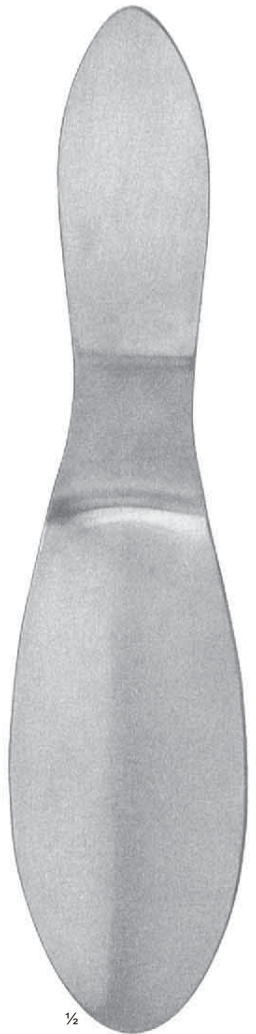

**REVERDIN**  
 17-628-01  
 28 cm, 11"

← Malleable, Biagsam, Maleable, Malléable, Malleabile →

